



Product Change Notification

Date Issued :	July 11, 2022	PCN Number :	511893
Reason for Change :	Equipment Transfer, Production Transfer or Rearrangement		
Description of Change :	Production plant change for parts which were moved to Poland from Guadalajara.		
Reason for Short Notice :	Capacity Increase		
Assessment of Change :	First Article Inspection		
Planned Implementation Date :	July 22, 2022		
Sample Availability Date:	April 08, 2022		
Internal Molex Qualification Date :	April 08, 2022		
Last date to request Samples by Customer :	July 04, 2022		
Traceability Code Markings / Date :	No special marking on the product or packaging		

Before Picture

- Examples products shown below

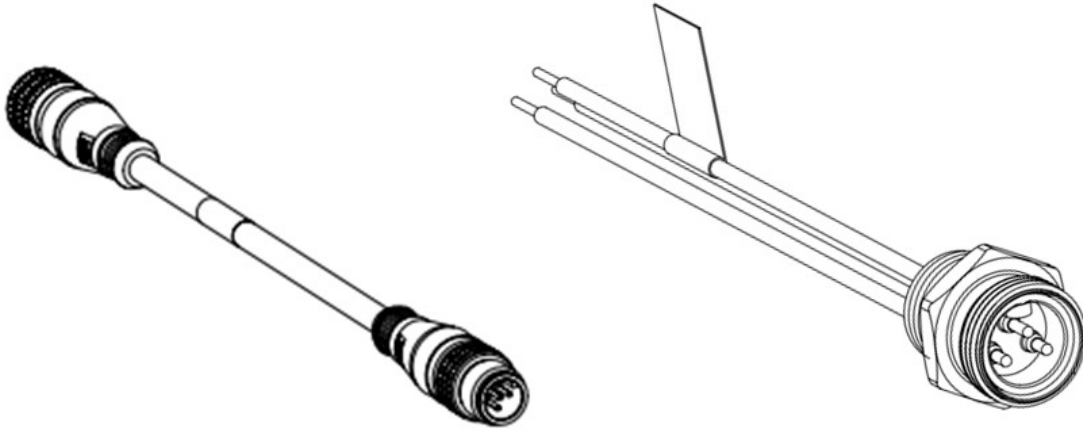

After Picture

Overview

- Only production plant change for parts which were moved to Poland from Guadalajara. This is only to add capacity. No change to components or the finished goods.
- No impact to fit, form or function.
- Part Number Impact
 - See attached impacted parts list

RELEASED

You may address inquiries regarding this PCN by clicking on the below link
mailto:pcn_coordinator@molex.com?subject=PCN_Notification:511893
or contact your Local Sales Engineer.

Note: While responding, please retain " PCN Notification : **PCN Notification: 511893** " in the e-mail Subject line for faster response.

[Molex, LLC](#)
2222 Wellington Court
Lisle, IL 60532
TEL (800) 786-6539
www.molex.com