

Current Transducer HAS 200-S/SP105

For the electronic measurement of currents: DC, AC, pulsed..., with galvanic separation between the primary circuit and the secondary circuit.

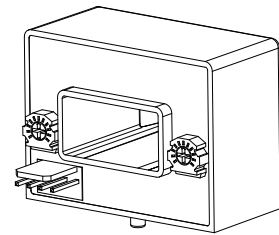

$$I_{PN} = 200 \text{ A}$$



Electrical data

I_{PN}	Primary nominal RMS current	200	A
I_{PM}	Primary current, measuring range	0 ... ± 600	A
U_C	Supply voltage ($\pm 5\%$) ¹⁾	± 15	V
I_C	Current consumption	± 15	mA
R_{INS}	Insulation resistance @ 500 V DC	> 1000	M Ω
U_{out}	Output voltage (Analog) @ $\pm I_{PN}$, $R_L = 10 \text{ k}\Omega$, $T_A = 25^\circ\text{C}$	$\pm 4 \text{ V} \pm 40$	V
R_{out}	Output internal resistance approx	100	Ω
R_L	Load resistance ²⁾	> 1	k Ω

Accuracy - Dynamic performance data

ε	Error @ I_{PN} , $T_A = 25^\circ\text{C}$ (excluding offset)	< ± 1	%
ε_L	Linearity error ³⁾ (0 ... $\pm I_{PN}$)	< ± 1	% of I_{PN}
U_{OE}	Electrical offset voltage, $T_A = 25^\circ\text{C}$	< ± 20	mV
U_{OH}	Hysteresis offset voltage @ $I_{PN} = 0$, after an excursion of $1 \times I_{PN}$	< ± 20	mV
TCU_{OE}	Temperature coefficient of U_{OE}	-40 $^\circ\text{C}$... +85 $^\circ\text{C}$ +85 $^\circ\text{C}$... +105 $^\circ\text{C}$	< ± 1 < ± 1.5 mV/K mV/K
TCU_{out}	Temperature coefficient of U_{out} (% of reading)	< ± 0.1	%/K
t_{D90}	Delay time to 90 % of I_{PN} ⁴⁾	< 3	μs
BW	Frequency bandwidth (-3 dB) ⁵⁾	DC ... 50	kHz

General data

T_A	Ambient operating temperature	-40 ... +105	$^\circ\text{C}$
T_S	Ambient storage temperature	-40 ... +105	$^\circ\text{C}$
m	Mass approx	60	g
	Standard	EN 50178: 1997 UL 508: 2010 ⁶⁾	

- Notes:** ¹⁾ Operating at $\pm 12 \text{ V} \leq U_C < \pm 15 \text{ V}$ will reduce the measuring range
²⁾ If the customer uses 1 k Ω of the load resistor, the primary current has to be limited as the nominal; To measure the full defined measuring range, the load resistor should be at minimum 10 k Ω
³⁾ Linearity data exclude the electrical offset
⁴⁾ For a $di/dt = 50 \text{ A}/\mu\text{s}$
⁵⁾ Please refer to derating curves in the technical file to avoid excessive core heating at high frequency
⁶⁾ UL conform at 85 $^\circ\text{C}$.

Features

- Hall effect measuring principle
- Insulating plastic case recognized according to UL 94-V0.

Special features

- Counter bored hole for transducer fastening
- $T_A = -40^\circ\text{C} \dots +105^\circ\text{C}$.

Advantages

- Easy mounting
- Small size and space saving
- Low power consumption
- Only one design for wide current ratings range
- High immunity to external interference.

Applications

- AC variable speed drivers and servo drives
- Static converters for DC motor drives
- Battery supplied applications
- Uninterruptible Power Supplies (UPS)
- Switched Mode Power Supplies (SMPS)
- Power supplies for welding applications.

Application domain

- Industrial.

Current Transducer HAS 200-S/SP105

Insulation coordination

U_d	RMS voltage for AC insulation test, 50 Hz/1 min	3.6	kV
U_{Ni}	Impulse withstand voltage 1.2/50 μ s	> 6.6	kV
		Min	
d_{CP}	Creepage distance	7.08	mm
d_{CI}	Clearance	6.23	mm
CTI	Comparative tracking index (group IIIa)	275	

Applications examples

According to EN 50178 and IEC 61010-1 standards and following conditions:

- Over voltage category OV 3
- Pollution degree PD2
- Non-uniform field

	EN 50178	IEC 61010-1
d_{CP}, d_{CI}, U_{Ni}	Rated insulation voltage	Nominal voltage
Basic insulation	600 V	600 V
Reinforced insulation	300 V	300 V

Safety

This transducer must be used in limited-energy secondary circuits according to IEC 61010-1.



This transducer must be used in electric/electronic equipment with respect to applicable standards and safety requirements in accordance with the manufacturer's operating instructions.



Caution, risk of electrical shock

When operating the transducer, certain parts of the module can carry hazardous voltage (eg. primary busbar, power supply).

Ignoring this warning can lead to injury and/or cause serious damage.

This transducer is a build-in device, whose conducting parts must be inaccessible after installation.

A protective housing or additional shield could be used.

Main supply must be able to be disconnected.

Dimensions HAS 200-S/SP105 (in mm)

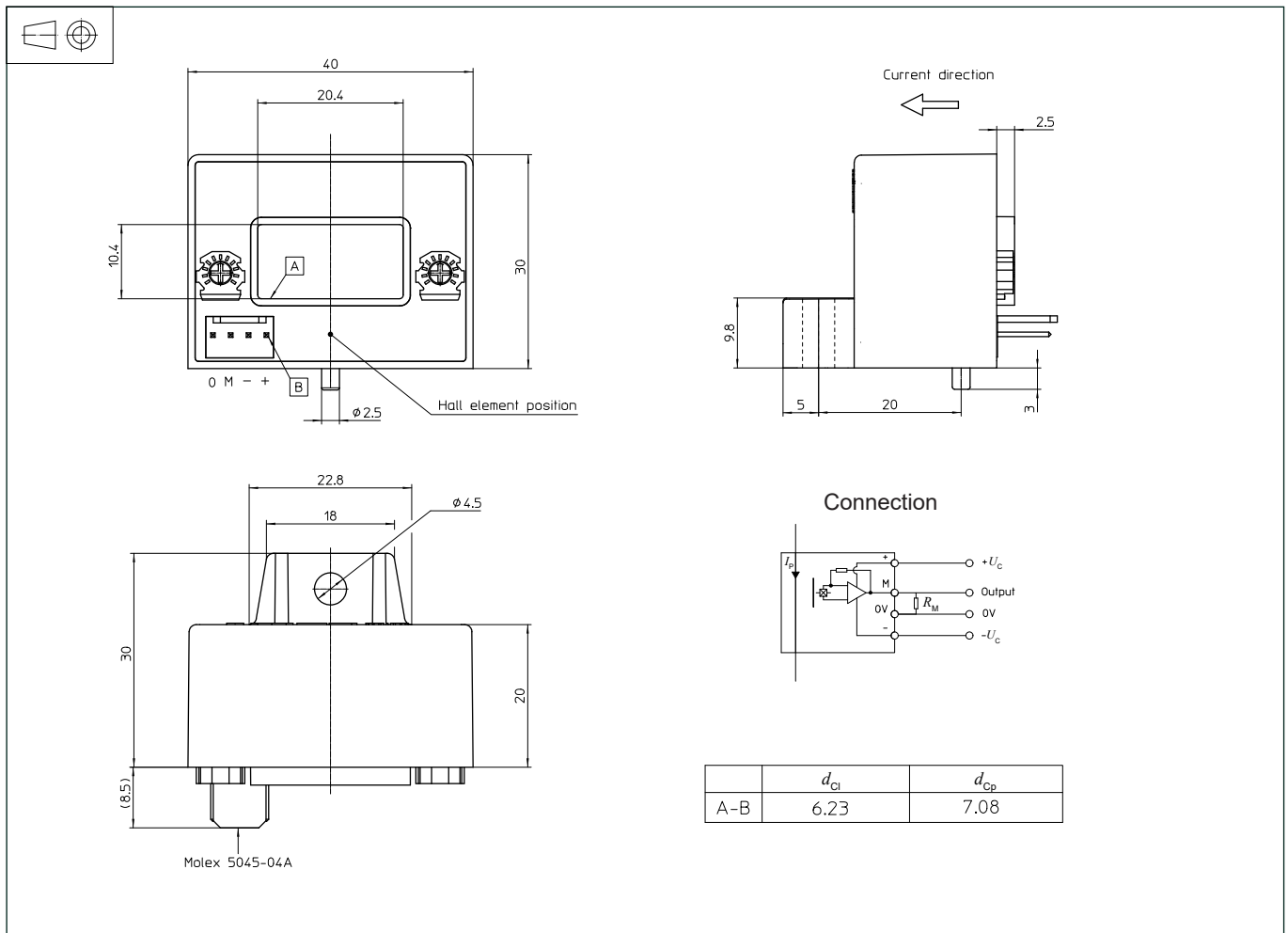

Mechanical characteristics

- General tolerance ± 0.5 mm
- Transducer fastening
1 hole $\varnothing 4.5$ mm
1 M4 steel screw
Recommended fastening torque 0.75 N·m ($\pm 10\%$)
- Connection of secondary Molex 5045-04A

Remarks

- U_{out} is positive when I_p flows in the direction of the arrow.
- Temperature of the primary conductor should not exceed 105 °C.
- Installation of the transducer must be done unless otherwise specified on the datasheet, according to LEM Transducer Generic Mounting Rules. Please refer to LEM document N°ANE120504 available on our Web site: <https://www.lem.com/en/file/3137/download/>.
- Dynamic performances (di/dt and delay time) are best with a single bar completely filling the primary hole.