

RoHS

REV.	EC#	DESCRIPTION	DATE	DRAWING	CHECKED	APPROVED
------	-----	-------------	------	---------	---------	----------

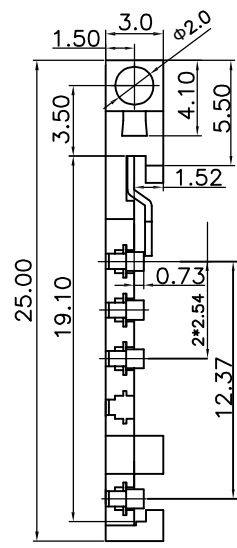
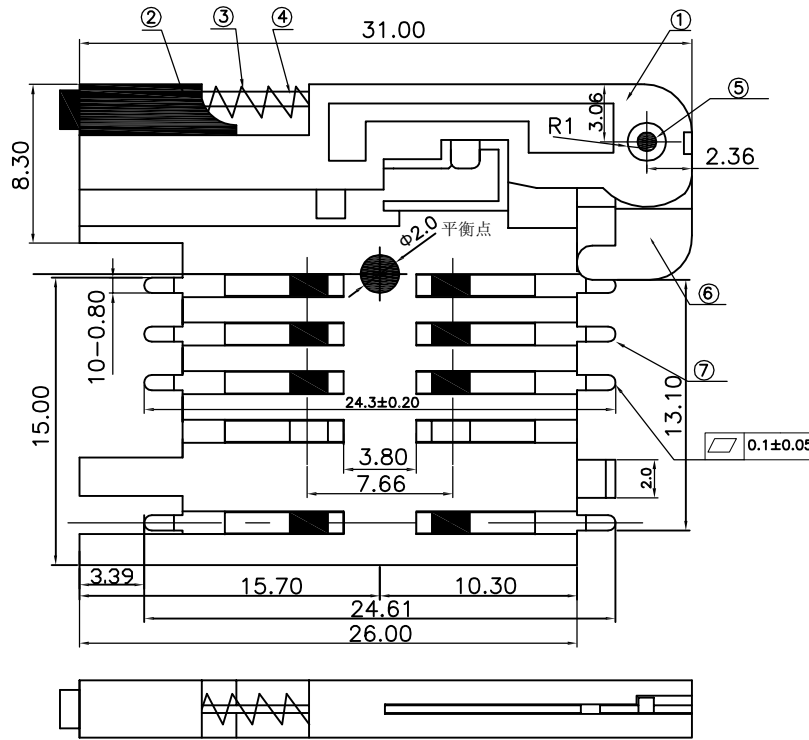

MATERIAL:
 1.CONTACT: COPPER ALLOY
 2.PLATING: SELECTIVE AU ON MATING AREA,TIN ON SOLDER ARER;
 3.HOUSING: LCP

MECHANICAL:
 1.PIN COUNT: 8PIN
 2.DURABILITY:10000 CYCLES;
 3.CONTACT NORMAL FORCE:0.2KG~0.6KG

ELECTRICAL
 1.INSULATION RESISTANCE:1000MΩ MIN.
 2.CONTACT RESISTANCE:100mΩMAX
 3.CD FUNCTION: NORMALLY OPEN

ENVIRONMENT
 1.OPERATION TEMPERATURE:-40°C~+85°C
 2.SOLDER CONDITION:265°C 5S

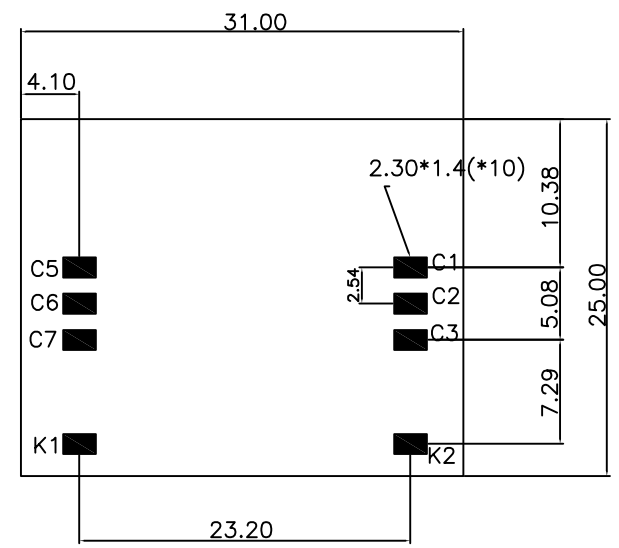

PCB LAYOUT

7	Contact	Phosphor copper	8	The bottom layer is plated with Ni; Au20~* plating in contact area
6	Z-piece	stainless steel	1	
5	Minor axis	Brass	1	
4	Push rod	Manganese Steel	1	
3	Spring	stainless steel	1	
2	Button	LCP	1	
1	Bracket	LCP	1	

MILLIMETERS	INCH	UNITS	慈溪市卡连电子有限公司 CIXI CARDCONN ELECTRONIC CO.,LTD
X° ± 2'	X° ±	MM	
X ± 0.30	.XX ±	MAT'L	PART NUMBER: SCC102154002
.XX ± 0.20	.XXX ±	SEE NOTES	
.XXX ± 0.10	.XXXX ±	FINISH	APPD: SCC-102154002
THESE DRAWINGS AND SPECIFICATIONS ARE THE PROPERTY OF CIXI CARDCONN ELECTRONIC CO.,LTD COPIED OR USED IN ANY MANNER WITHOUT THE PRIOR WRITTEN CONSENT OF CIXI CARDCONN ELECTRONIC CO.,LTD			
QTY			DR:
SEE NOTES			
TITLE: 抽屉式SIM 8PIN(6+2) 弹片式卡座带推杆			DWG NO.:
SCALE			1:1
SHEET			1/3
REV.			A0

RoHS

REV.	EC#	DESCRIPTION	DATE	DRAWING	CHECKED	APPROVED
------	-----	-------------	------	---------	---------	----------

A

B

C

D

E

SIM

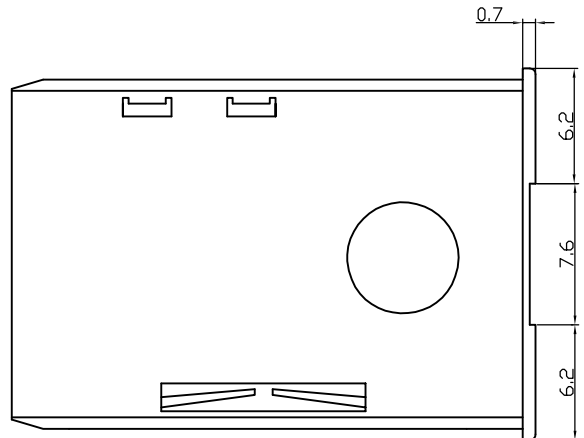
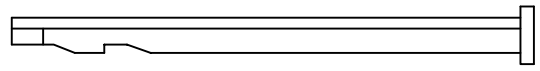
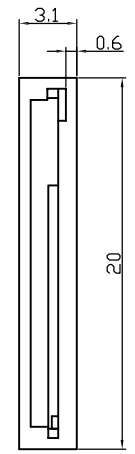
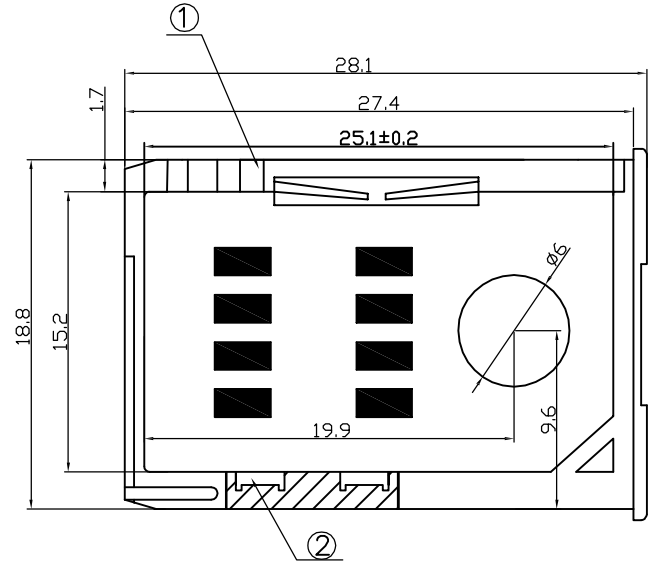

Technical requirements:

1. The product appearance is free of dirt, scratches and deformation,
2. The plastic is free of burrs and mold filling, and the contact piece is free of oxidation and rust

MILLIMETERS	INCH	UNITS	慈溪市卡连电子有限公司 CIXI CARDCONN ELECTRONIC CO.,LTD			
X° ± 2'	X° ±	MM	PART NUMBER: SCC102154002	TITLE: 抽屉式SIM 8PIN(6+2) 弹片式卡座带推杆		
.X ± 0.30	.XX ±	MAT'L		APPD:	DWG NO.: SCC-102154002	
.XX ± 0.20	.XXX ±	SEE NOTES	CHKD:	SCALE	SHEET	REV.
.XXX ± 0.10	.XXXX ±	FINISH	DR:	1:1	2/3	A0
THESE DRAWINGS AND SPECIFICATIONS ARE THE PROPERTY OF CIXI CARDCONN ELECTRONIC CO.,LTD COPIED OR USED IN ANY MANNER WITHOUT THE PRIOR WRITTEN CONSENT OF CIXI CARDCONN ELECTRONIC CO.,LTD			QTY			
			SEE NOTES			

1

2

3

4

5

RoHS

REV.	EC#	DESCRIPTION	DATE	DRAWING	CHECKED	APPROVED
------	-----	-------------	------	---------	---------	----------

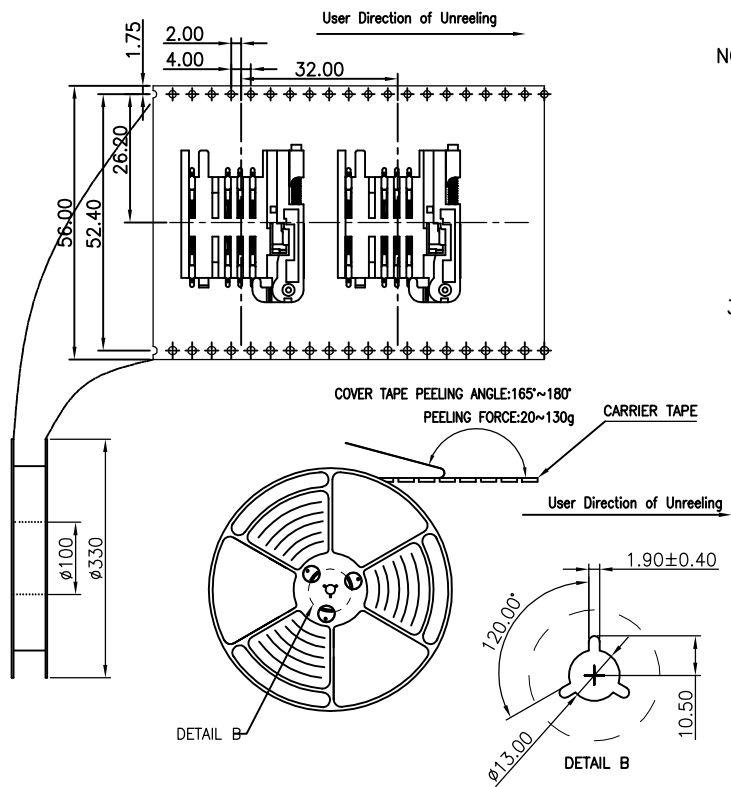
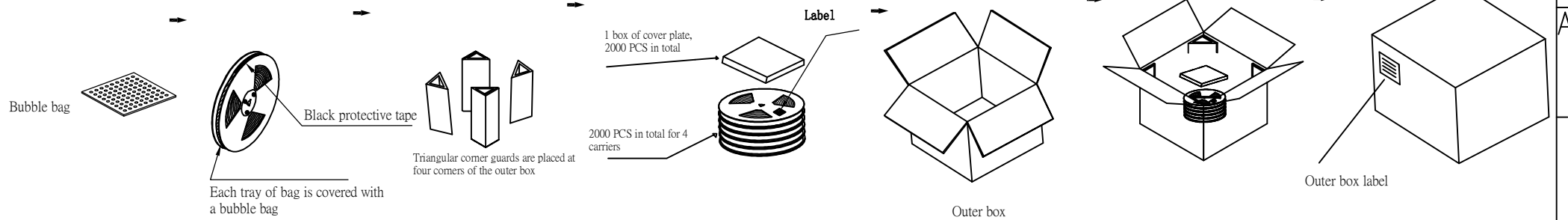

NOTES

- NUMBER OF CONNECTORS: 500PCS/REEL
- LEAD TAPE LENGTH
- QUANTITY: 2000PCS/CARTON

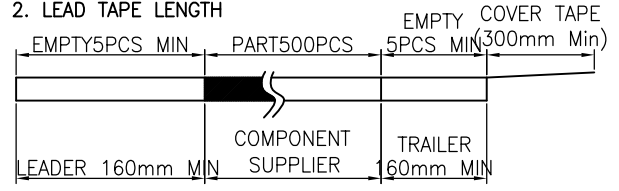

MILLIMETERS	INCH	UNITS	 慈溪市卡连电子有限公司 CIXI CARDCONN ELECTRONIC CO., LTD
X° ± 2'	X° ±	MM	
.X ± 0.30	.XX ±	MAT'L	PART NUMBER: SCC102154002
.XX ± 0.20	.XXX ±	SEE NOTES	
.XXX ± 0.10	.XXXX ±	FINISH	APPD:
THESE DRAWINGS AND SPECIFICATIONS ARE THE PROPERTY OF CIXI CARDCONN ELECTRONIC CO.,LTD COPIED OR USED IN ANY MANNER WITHOUT THE PRIOR WRITTEN CONSENT OF CIXI CARDCONN ELECTRONIC CO.,LTD			
QTY			CHKD:
SEE NOTES			DWG NO.: SCC-102154002
			SCALE
			SHEET
			REV.
			1:1
			3/3
			A0

