

Product Specification

Abundance Enterprise Co.

Date

10/1/2007

PN:

SX4025



AEC[®]

Abundance Enterprise Co.

PRODUCT SPECIFICATION

CRYSTAL RESONATOR

AEC PART NUMBER / SPEC. NO: SX4025-12M-AF-30/30-80Ω-18p

CUSTOMER: QUARTZ-1 LTD



Compliant

This model is ROHS/PB-free compliance according to the ROHS directive 2002/95/EC

Customer's Name	QUARTZ-1 LTD
Production Name	Crystal Resonator
Frequency	12.0 MHz
Model No	SX4025-12M-AF-30/30-80Ω-18p
Issue Date	16 th March, 2009

Address: Room 602-603, Java Commercial Centre,

128 Java Road,

North Point, Hong Kong

Homepage: <http://www.aeccrystal.com/>

Email: sales@aeccrystal.com

Telephone: (852)-28560000

Prepared	Inspection	Approved
<i>Nathan</i>	<i>Andy</i>	<i>Henkie</i>

1. GENERAL PROVISION

- 1-1 Production Name: SMD Crystal Resonator
 1-2 Holder Type: SX4025- 4 PADS
 1-3 This specification relates to the crystal resonator to be supplied by Abundance Enterprise Co. (AEC).

2. ELECTRICAL DATA

Items	Parameters	Condition
2-1	Frequency:	12.0 MHz
2-2	Mode of Oscillation:	Fund.
2-3	Tolerance of Center Frequency:	+/- 30 ppm at 25°C
2-4	Frequency Stability:	+/-30 ppm in 2-5
2-5	Operating Temperature Range:	-20 °C to 70 °C
2-6	Storage Temperature Range:	-40°C to +85°C
2-7	Equivalent Series Resistance:	80Ω max.
2-8	Load Capacitance:	18 pF
2-9	Shunt Capacitance:	7 pF
2-10	Drive Level:	0.1 mW
2-11	Aging: Less than	+/- 5 ppm per year
2-12	Insulation Resistance:	More than 500M ohms at DC 100V
2-13	Test Set	KH1200

3. ENVIRONMENTAL TEST CONDITION

The following are our reliability test condition and criteria.

Items	Test Method and Criteria
3-1 Drop Test	Free falling from height 750mm, plate 30mm to thick hard wood board 3 times
3-2 Vibration test	Vibrating frequency 10-500Hz, amplitude 1.5mm X, Y, Z directions each 2 hours
3-3 Rough leakage check	Water temperature 80-85 °C , crystal above water 2.5mm for more than 1 minute to see if sample has any prominent continuous gas bubble comes out
3-4 Solderability	Solder 63/37, temperature 260°C, time: 5 sec, eye checking soldering area is greater or equal to electrode area 3/4
3-5 Reflow soldering	Reflow soldering system, peak temperature 260°C, time: 10 sec, Test $\Delta f/f \leq \pm 3\text{ppm}$
3-6 Precise leakage check	Helium spectro leakage checker, leakage rate $\leq 5 \times 10^{-8} \text{atm.CC/S}$

Each test is independently examined.

4. DIMENSION & LAND PATTERN

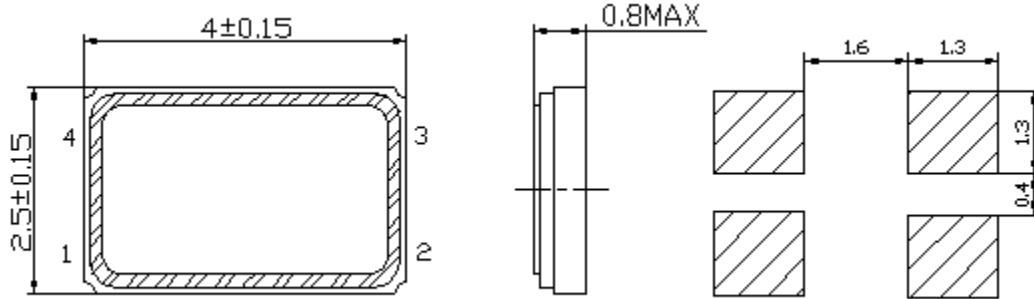

Recommended Land

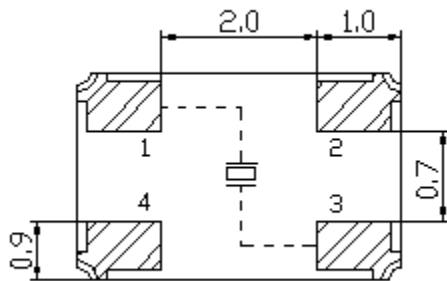

Unit: mm

AEC [®] Abundance Enterprise Co.	NO.	DATE	MODIFY CONTENTS		
	1	2005.12.1	NEW EDITION		
DIMENTION	mm				
SCALE	/	PART NAME	Crystal Resonator		
TOLERANCE	±0.2	MODEL	SX4025		
DRAWING NO.	DATE	APPV'D BY	CHECK BY	DRAWN BY	
SX4025	2006.12.1	Henkie	Andy	Nathan	

5. MARKING

<p>Example</p> <p>Remarks:</p> <p>1) Frequency- CL</p> <p>2) Logo – Date code</p>	
--	--

6. SOLDER REFLON DIAGRAM

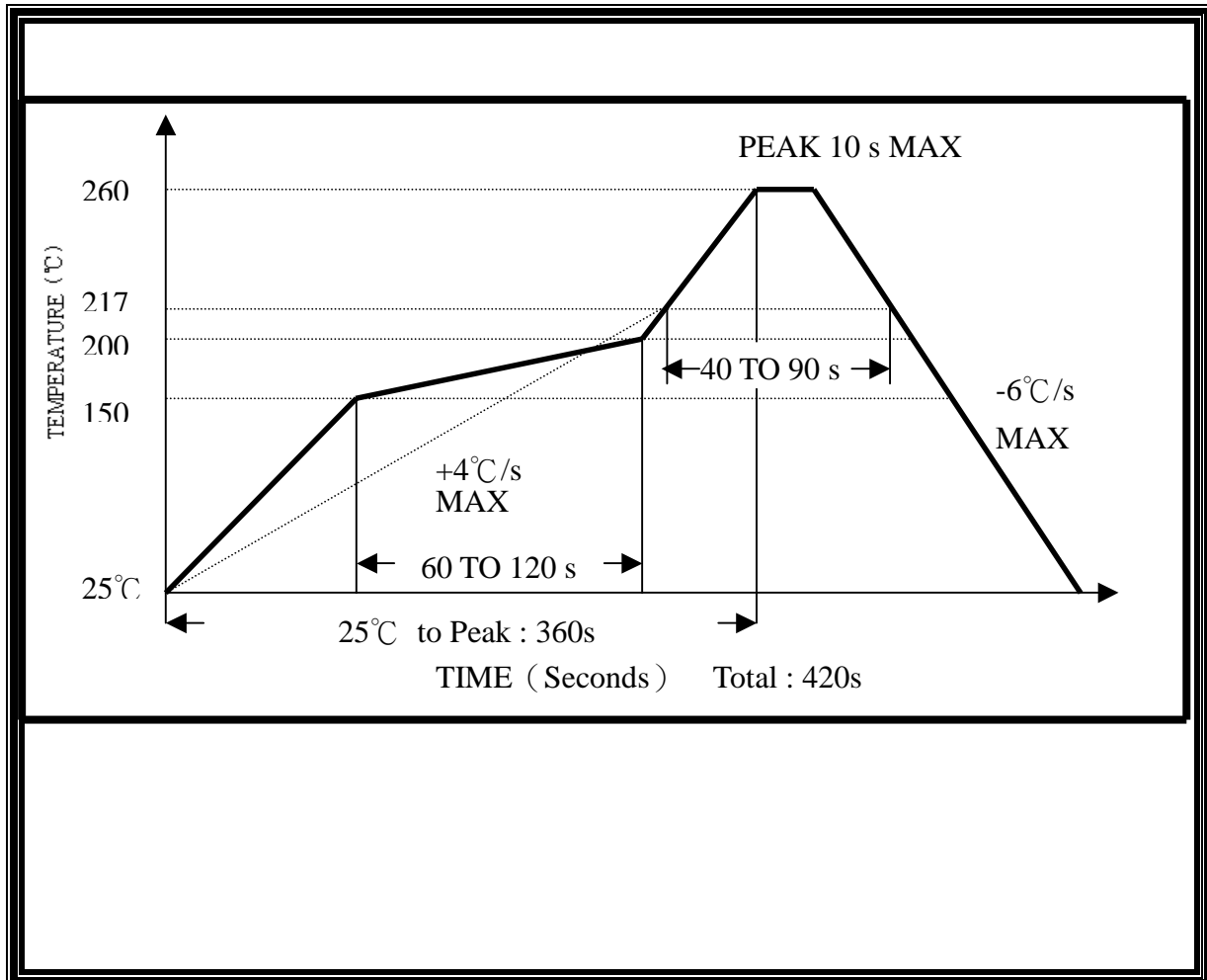

7. TAPE AND REEL

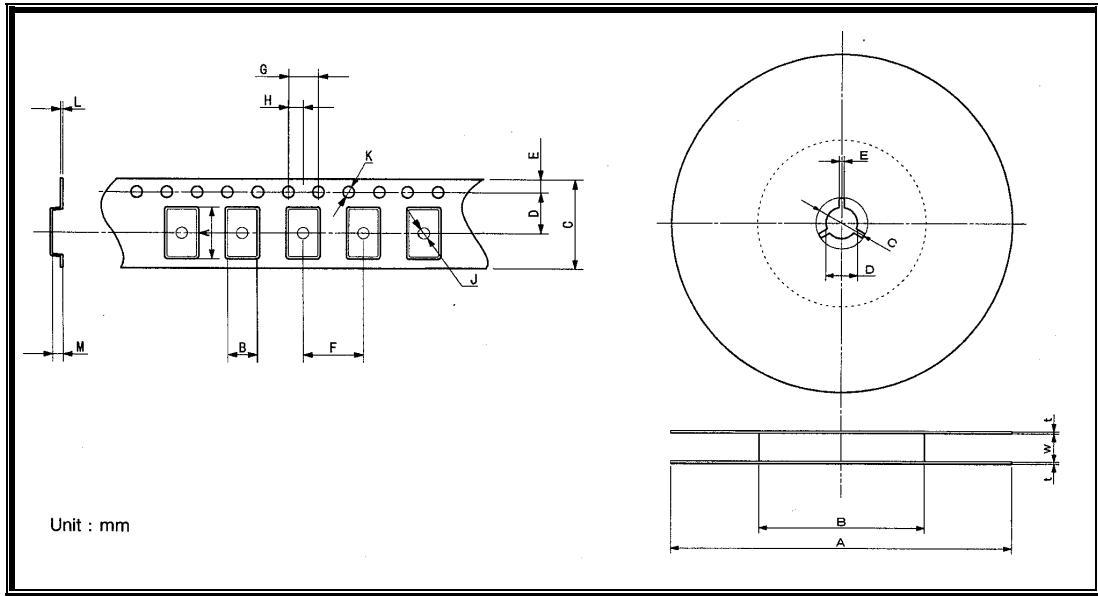

TAPE DIMENSION

A	B	C	D	E	F	G	H	J	K	L	M
5.5	3.7	12.0	5.5	1.75	8.0	4.0	2.0	Φ1.5	Φ1.5	0.3	1.1

REEL DIMENSION

A	B	C	D	E	W
178	Φ80	Φ21.0	Φ13.0	2.5	12.4

8.