

## HMIC™ PIN Diode SP2T 20 Watt Switch for 0.05 - 6.0 GHz Higher Power Applications

Rev. V5

### Features

- Exceptional Broadband Performance, 0.05 - 6.0 GHz
- Low Loss: Tx = 0.24 dB Avg @ 2025 MHz, 35mA
- Tx = 0.38 dB Avg @ 3500 MHz, 35mA
- High Isolation: Rx = 31.0 dB Avg @ 2025 MHz
- Rx = 27 dB Avg @ 3500 MHz
- High RF C.W. Input Power: 20 W C.W. (Tx-Ant Port)
- Higher IIP3: > 64 dBm (Tx-Ant Port)
- Suitable for High Power TD-SCDMA & WiMAX Applications
- Surface Mount 3mm PQFN Package
- RoHS\* Compliant and 260°C Re-flow Compatible

### Description and Applications

The MASW-000825-12770T is a compact SP2T PIN diode switch in a lead-free 3mm MLP plastic package that offers extraordinary performance with excellent isolation to loss ratio for both Tx and Rx states. The SP2T provides outstanding 20 W C.W. power handling coupled with 64 dBm IIP3 for maximum switch performance.

The MASW-000825-12770T is a 0.05 - 6.0GHz SP2T High Peak and Average Power PIN diode switch used for T/R or LNA Protect Switch applications such as WiMAX and TD-SCDMA.

This device incorporates a PIN diode die fabricated with M/A-COM Technology Solutions patented Silicon-Glass HMIC™ process. This chip features two silicon pedestals embedded in a low loss, low dispersion glass. The diodes are formed on the top of each pedestal. The topside is fully encapsulated with silicon nitride and has an additional polymer passivation layer. These polymer protective coatings prevent damage and contamination during handling and assembly.

### Ordering Information

Part Number	Package
MASW-000825-12770T	1000 piece reel
MASW-000825-001SMB	Sample Board
MADR-008888-0002TB	Sample Board with recommended external Driver & MASW-000825-12770T Switch

### Functional Diagram (TOP VIEW)

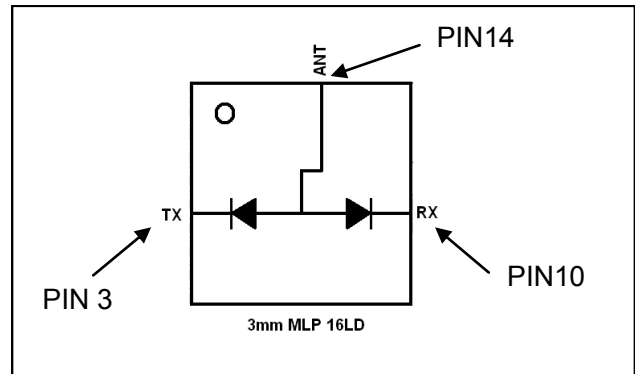

### Circuit Side View

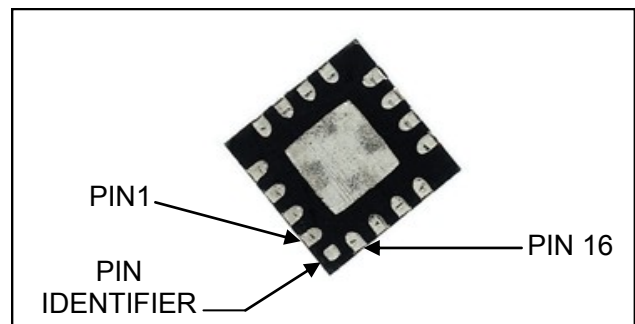

### Pin Configuration:

(Center Metal Area is RF, D.C., and Thermal Ground)

PIN	Function	PIN	Function
1	N/C	9	GND
2	GND	10	Rx
3	Tx	11	GND
4	GND	12	N/C
5	N/C	13	GND
6	N/C	14	Ant
7	N/C	15	GND
8	N/C	16	N/C

\* Restrictions on Hazardous Substances, European Union Directive 2002/95/EC.

## HMIC™ PIN Diode SP2T 20 Watt Switch for 0.05 - 6.0 GHz Higher Power Applications

Rev. V5

### Electrical Specifications at +25°C, Characteristic Impedance $Z_0 = 50 \Omega$ , 35mA/28V

Parameter	Symbol	35mA / 28V Conditions	Units	Min.	Typ.	Max.
<b>F = 2.0-2.7 GHz</b>						
Insertion Loss, Rx	Rx, IL	Bias: See Table Below, Pinc= 0 dBm	dB		0.42	0.55
Insertion Loss, Tx	Tx, IL	Bias: See Table Below, Pinc= 0 dBm	dB		0.29	0.38
Isolation, Tx To Rx	Rx, ISO	Bias: See Table Below, Pinc= 0 dBm	dB	24.5	28.6	
Isolation, Rx To Tx	Tx, ISO	Bias: See Table Below, Pinc= 0 dBm	dB	21.3	24.2	
Tx Input Return Loss	Tx, RL	Bias: See Table Below, Pinc= 0 dBm	dB		- 28	
Rx Input Return Loss	Rx, RL	Bias: See Table Below, Pinc= 0 dBm	dB		- 28	
<b>F = 3.3-3.8 GHz</b>						
Insertion Loss, Rx	Rx,IL	Bias: See Table Below, Pinc= 0 dBm	dB		0.56	0.71
Insertion Loss, Tx	Tx, IL	Bias: See Table Below, Pinc= 0 dBm	dB		0.38	0.48
Isolation, Tx To Rx	Rx, ISO	Bias: See Table Below, Pinc= 0 dBm	dB	22	26	
Isolation, Rx To Tx	Tx, ISO	Bias: See Table Below, Pinc= 0 dBm	dB	19.7	21.6	
Tx Input Return Loss	Tx, RL	Bias: See Table Below, Pinc= 0 dBm	dB		- 28	
Rx Input Return Loss	Rx, RL	Bias: See Table Below, Pinc= 0 dBm	dB		-28	
<b>F = 4.9-5.9 GHz</b>						
Insertion Loss, Rx	Rx, IL	Bias: See Table Below, Pinc= 0 dBm	dB		0.95	1.10
Insertion Loss, Tx	Tx, IL	Bias: See Table Below, Pinc= 0 dBm	dB		0.59	0.71
Isolation, Tx To Rx	Rx, ISO	Bias: See Table Below, Pinc= 0 dBm	dB	19.5	22.4	
Isolation, Rx To Tx	Tx, ISO	Bias: See Table Below, Pinc= 0 dBm	dB	16.5	18.5	
Tx Input Return Loss	Tx, RL	Bias: See Table Below, Pinc= 0 dBm	dB		- 25	
Rx Input Return Loss	Rx, RL	Bias: See Table Below, Pinc= 0 dBm	dB		- 24	

Port	Tx	Rx	ANT
Pin	Pin 3	Pin 10	Pin 14
Tx-ANT Isolation	+28V @ 0 ma	0V	+ 5V @ 35 mA
Tx-ANT Insertion Loss	0V	+28V @ 0 ma	+ 5V @ 35 mA
Rx-ANT Isolation	0V	+28V @ 0 ma	+ 5V @ 35 mA
Rx-ANT Insertion Loss	+28V @ 0 ma	0V	+ 5V @ 35 mA

## HMIC™ PIN Diode SP2T 20 Watt Switch for 0.05 - 6.0 GHz Higher Power Applications

Rev. V5

### Electrical Specifications at +25°C, Characteristic Impedance, $Z_0 = 50 \Omega$

Parameter	Symbol	Conditions	Units	Min	Typ	Max
Tx 2 <sup>nd</sup> Harmonic	Tx 2Fo	Fo=2.010 GHz, Tx = +5.0 V@ +35mA, Rx =+28V @ 0mA Pin = + 30 dBm, Tx To Antenna	dBc		70	
Tx 3 <sup>rd</sup> Harmonic	Tx 3Fo	Fo= 2.010 GHz, Tx = +5.0 V@ +35mA, Rx =+28V @ 0mA Pin = + 30 dBm, Tx To Antenna	dBc		86	
Tx Input Third Order Intercept Point	Tx IIP3	Tx = +5.0 V@ +35mA, Rx =+28V @ 0mA Pi= +20 dBm, F1 = 2.010 GHz, F2 = 2.020 GHz, Tx To Antenna	dBm		64	
Tx C.W. Input Power <sup>2</sup>	Tx CW Pinc	Tx = +5.0 V@ +35mA, Rx =+28V @ 0mA F = 2.010, 3.500 GHz, Tx To Antenna	dBm W			43 20
Tx Peak Input Power	Tx Pk Pinc	Tx = +5.0 V@ +35mA, Rx =+28V @ 0mA F = 2.010 GHz, Tx To Antenna ( 5 $\mu$ S RF Pulse Width, 1% Duty 1.10:1 Ant VSWR )	dBm W			53 200
Rx C.W. Input Power	Rx CW Pinc	Rx = +5.0 V@ +35mA, Tx =+28V @ 0mA F = 2.010 GHz, Antenna to Rx	dBm W			39 8
Tx Input P1dB	Tx P1dB	Tx = +5.0 V@ +35mA, Rx =+28V @ 0mA F = 2.010, GHz, Tx To Antenna	dBm		>43	
Tx RF Switching Speed	$\tau_{RF}$	( 10% - 90% RF Voltage) Tx = +5.0 V@ +35mA, Rx =+28V @ 0mA F = 2.010 GHz, Tx To Antenna 1MHz Rep Rate in Modulating Mode	ns		200	

### Absolute Maximum Ratings<sup>1</sup> @ T<sub>A</sub> = +25 °C (unless otherwise specified)

Parameter	Absolute Maximum
Forward Current	100 mA
Reverse Voltage ( RF & D.C. )	-140 V
Operating Temperature	-40 °C to +85 °C
Storage Temperature	-55 °C to +150 °C
Junction Temperature	+175 °C
Tx Incident C.W. Power <sup>2</sup>	20 W C.W.
Tx Peak Incident Power With 3.0:1 Maximum Ant VSWR	150 W, 5 $\mu$ S P.W., 1% Duty

### Handling Procedures

Please observe the following precautions to avoid damage:

### Static Sensitivity

These devices are rated Class 1B Human Body. Proper ESD control techniques should be used when handling these devices.

1. Exceeding these limits may cause permanent damage.
2. Refer to page 7 of the datasheet for power handling curves.

## HMIC™ PIN Diode SP2T 20 Watt Switch for 0.05 - 6.0 GHz Higher Power Applications

Rev. V5

### D.C. Bias to RF Truth Table

RF State	TTL & D.C. Bias Conditions	Voltage at Common Anode
Low Loss Tx-Ant & Isolation Tx-Rx	TTL = 1 + 5V @ 35 mA ( Tx ), + 28V @ 0 mA ( Rx )	+ 0.9 V
Low Loss Ant-Rx & Isolation Rx-Tx	TTL = 0 + 5V @ 35 mA ( Rx ), + 28V @ 0 mA ( Tx )	+ 0.9 V

### Driver and SP2T Schematic with Positive Voltage

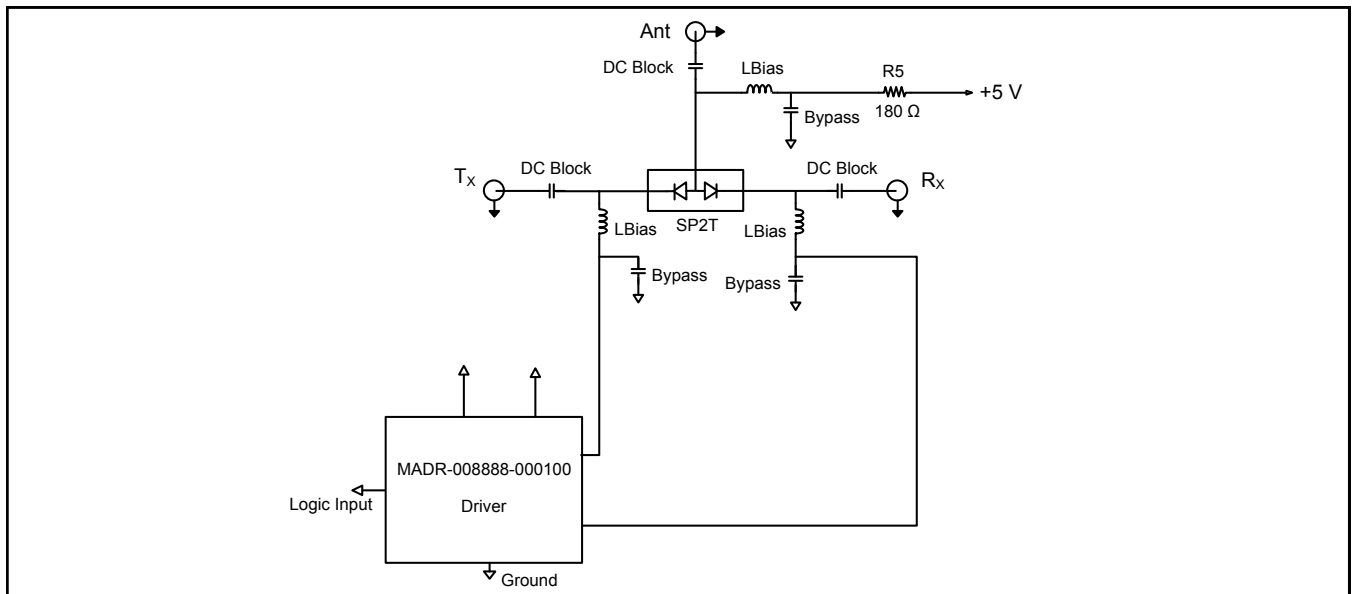

#### Notes:

1. Data is taken on M/A-COM evaluation board 1000029181-0000001 @ 25C by removing peripheral board losses ( connectors, transmission line, and bias elements ).
2. Typical PIN Diode Forward Voltage = + 0.9 V @ + 35 mA for Insertion Loss.  
Typical PIN Diode Reverse Voltage = 28 V – 1.0 V = 27 V for Isolation.
3. Switch is Asymmetrical, + 43 dBm RF C.W. Input Power Applies to Tx Port Only.
4. Center Ground Area of MLP 3mm Package must be Attached to Thermal Ground for Optimum RF Power Performance.
5. M/A-Com Recommends the usage of the [MADR-008888-000100](https://www.macom.com/products/madr-008888-000100) driver with this switch.

#### Assembly Note:

A typical soldering process profile and handling instructions are provided in Application Notes, [S2083](https://www.macom.com/support/notes/s2083) “Surface Mount Instructions for QFN / DFN Packages” on the M/A-Com website at [www.macomtech.com](https://www.macomtech.com)

**Typical Small Signal Performance at +25°C, Characteristic Impedance,  $Z_0 = 50 \Omega$**

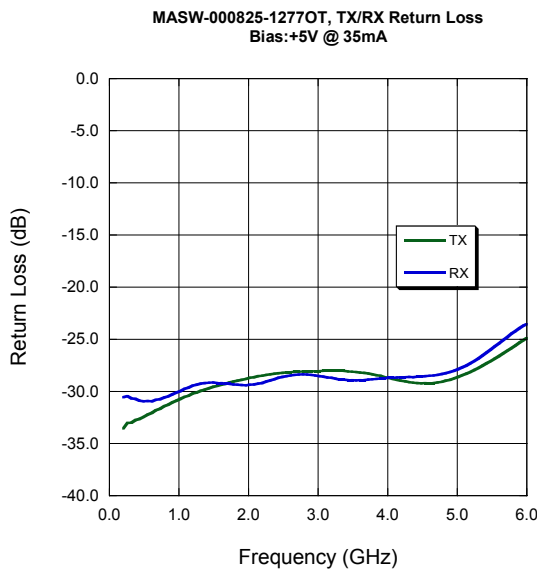
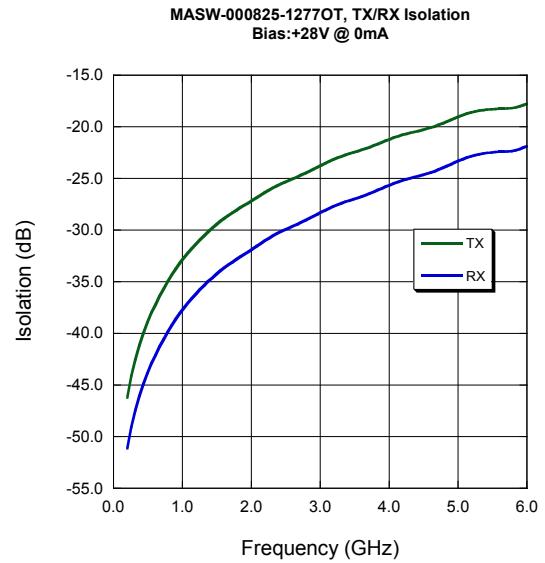
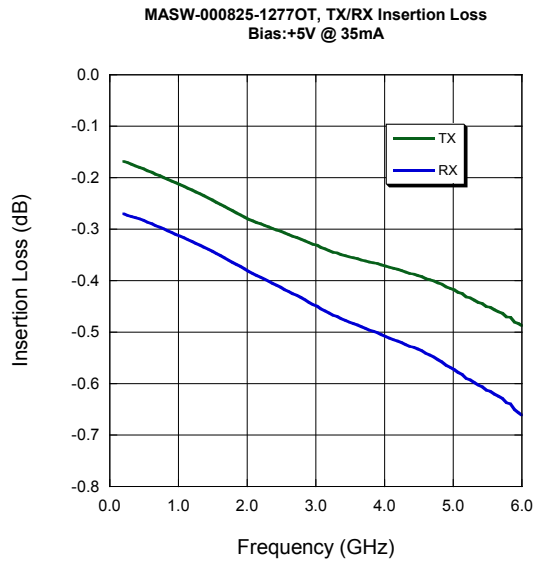

### Typical Small Signal Performance over Temperature Characteristic Impedance, $Z_0 = 50 \Omega$

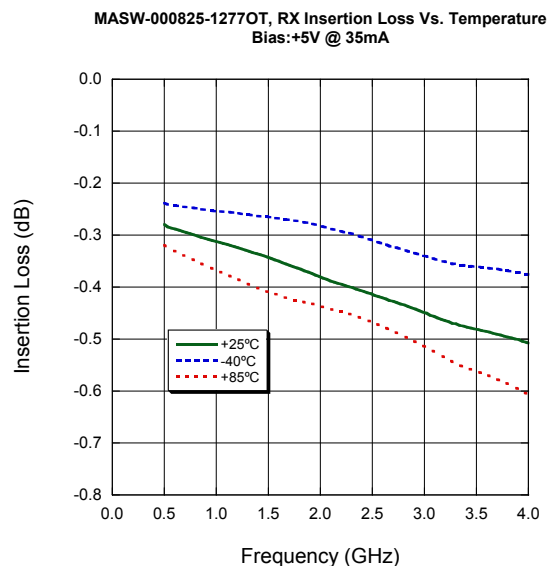
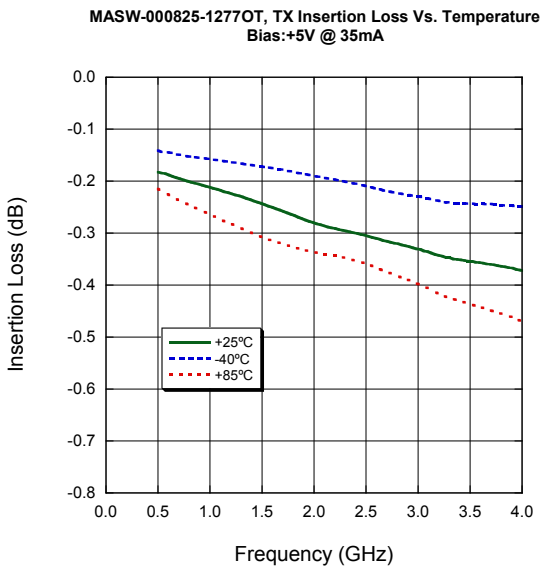
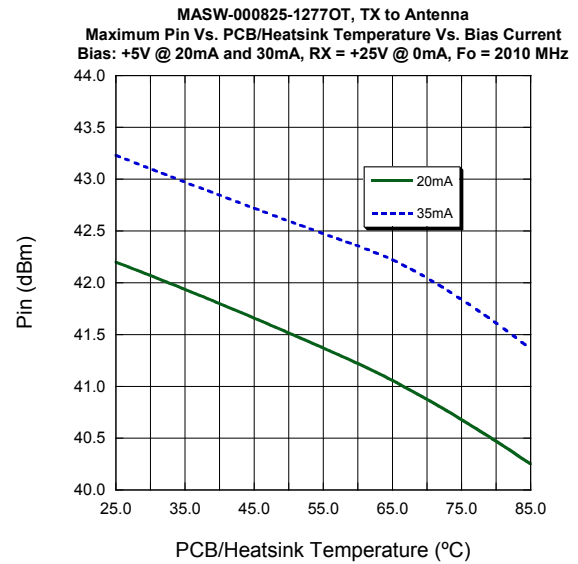
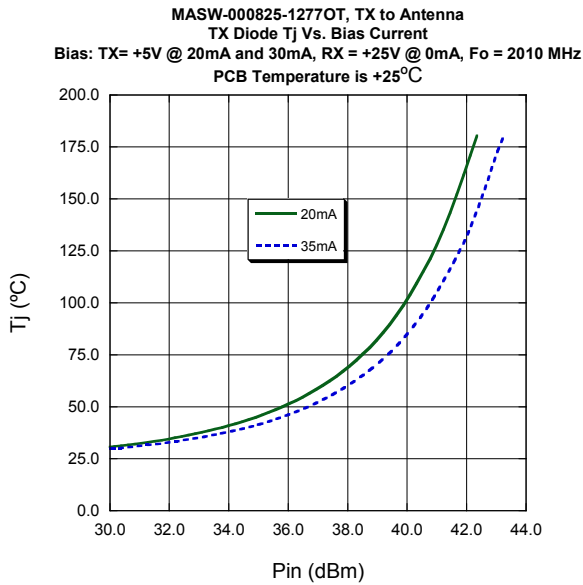

## Typical Small Signal Performance over temperature Characteristic Impedance, $Z_0 = 50 \Omega$

MASW-000825-12770T, TX Isolation Vs. Temperature  
Bias: +28V @ 0mA

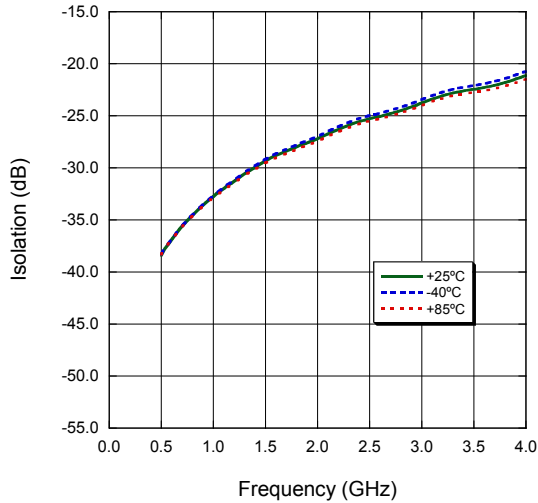

MASW-000825-12770T, RX Isolation Vs. Temperature  
Bias: +28V @ 0mA

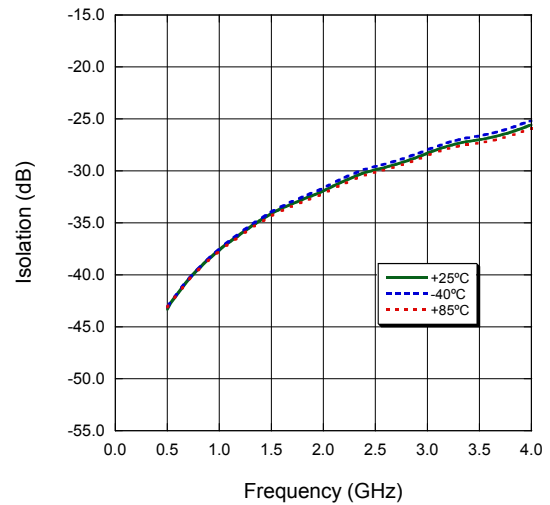

MASW-000825-12770T, TX Return Loss Vs. Temperature  
Bias: +5V @ 35mA

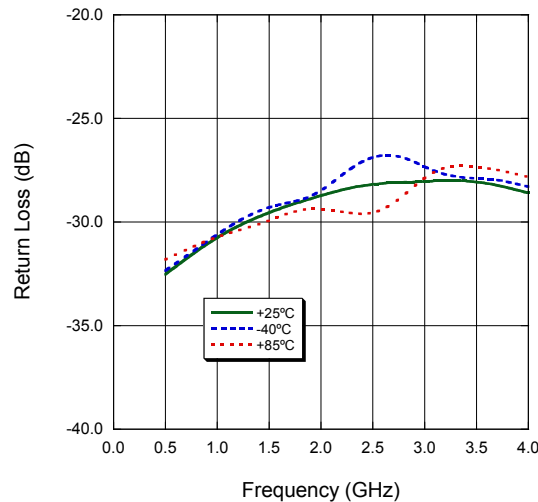

MASW-000825-12770T, RX Return Loss Vs. Temperature  
Bias: +5V @ 35mA

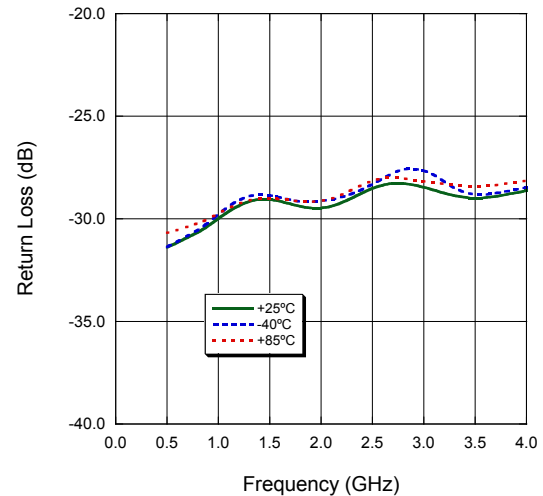

## HMIC™ PIN Diode SP2T 20 Watt Switch for 0.05 - 6.0 GHz Higher Power Applications

Rev. V5

### MASW-000825-12770T Outline† – Lead Free 3mm PQFP-N 16 Lead Saw Singulated

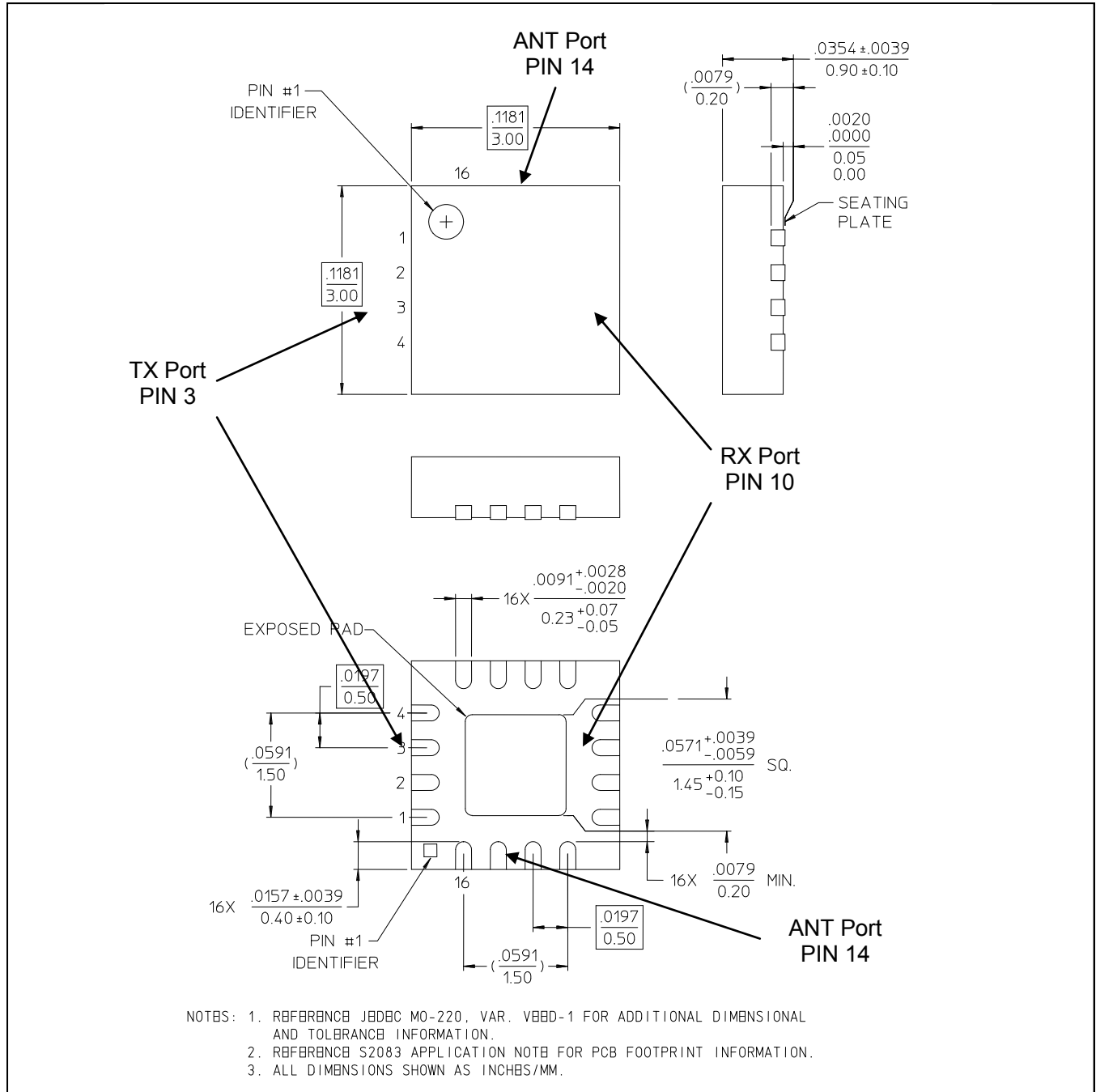

† Reference Application Note S2083 for lead-free solder reflow recommendations.  
Meets JEDEC moisture sensitivity level 1 requirements.



M/A-COM Technology Solutions Inc. All rights reserved.

Information in this document is provided in connection with M/A-COM Technology Solutions Inc ("MACOM") products. These materials are provided by MACOM as a service to its customers and may be used for informational purposes only. Except as provided in MACOM's Terms and Conditions of Sale for such products or in any separate agreement related to this document, MACOM assumes no liability whatsoever. MACOM assumes no responsibility for errors or omissions in these materials. MACOM may make changes to specifications and product descriptions at any time, without notice. MACOM makes no commitment to update the information and shall have no responsibility whatsoever for conflicts or incompatibilities arising from future changes to its specifications and product descriptions. No license, express or implied, by estoppel or otherwise, to any intellectual property rights is granted by this document.

THESE MATERIALS ARE PROVIDED "AS IS" WITHOUT WARRANTY OF ANY KIND, EITHER EXPRESS OR IMPLIED, RELATING TO SALE AND/OR USE OF MACOM PRODUCTS INCLUDING LIABILITY OR WARRANTIES RELATING TO FITNESS FOR A PARTICULAR PURPOSE, CONSEQUENTIAL OR INCIDENTAL DAMAGES, MERCHANTABILITY, OR INFRINGEMENT OF ANY PATENT, COPYRIGHT OR OTHER INTELLECTUAL PROPERTY RIGHT. MACOM FURTHER DOES NOT WARRANT THE ACCURACY OR COMPLETENESS OF THE INFORMATION, TEXT, GRAPHICS OR OTHER ITEMS CONTAINED WITHIN THESE MATERIALS. MACOM SHALL NOT BE LIABLE FOR ANY SPECIAL, INDIRECT, INCIDENTAL, OR CONSEQUENTIAL DAMAGES, INCLUDING WITHOUT LIMITATION, LOST REVENUES OR LOST PROFITS, WHICH MAY RESULT FROM THE USE OF THESE MATERIALS.

MACOM products are not intended for use in medical, lifesaving or life sustaining applications. MACOM customers using or selling MACOM products for use in such applications do so at their own risk and agree to fully indemnify MACOM for any damages resulting from such improper use or sale.