

Sensors

FESTO



You require easy running processes.
You want first-class sensor systems.
We have the right vision for achieving maximum productivity.

→ WE ARE THE ENGINEERS
OF PRODUCTIVITY.

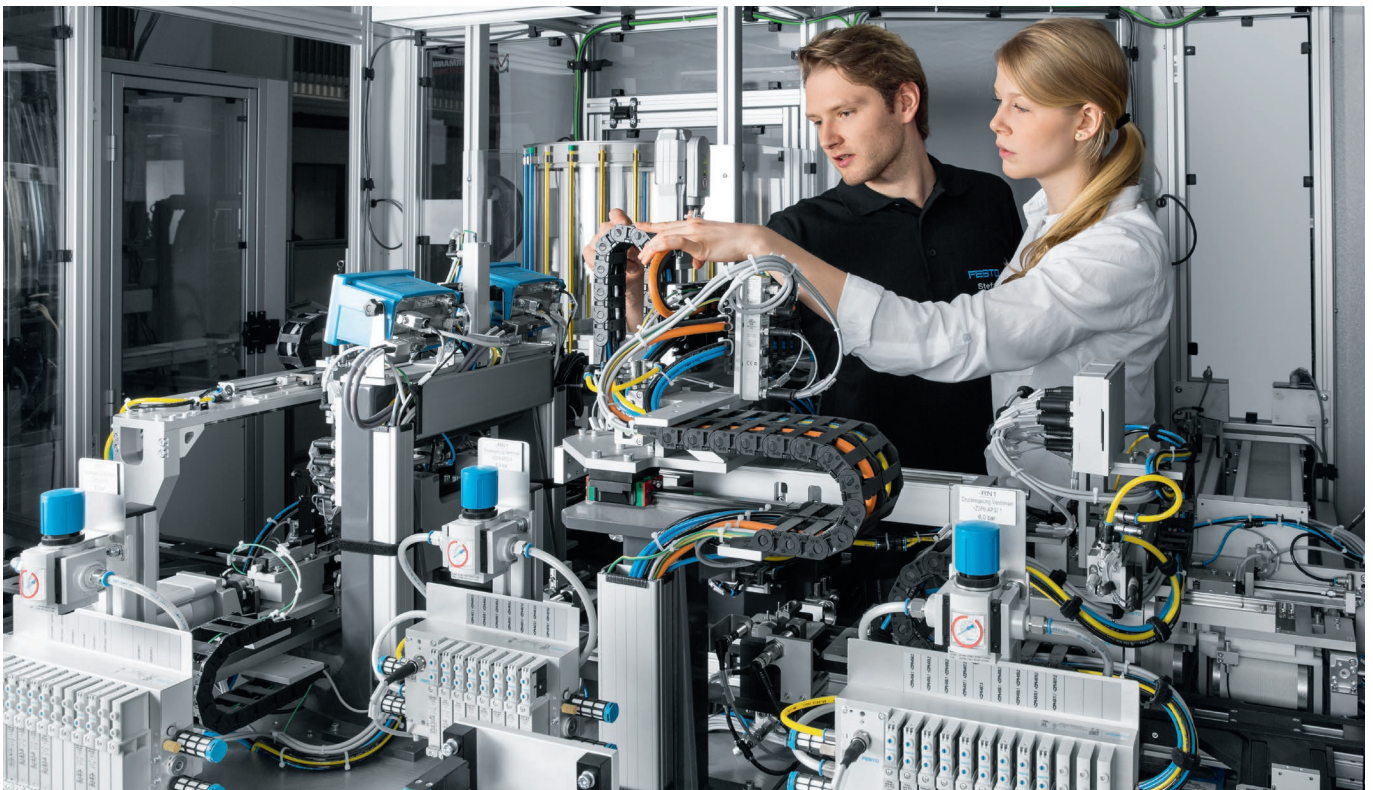

Page 4

Page 6

Page 8

Page 10

Proximity sensors

Position transmitters

Pressure and
vacuum sensors

Flow sensors

Festo sensors – for successful automation from a single source

In focus: Festo sensors

Increased cycle times, better process control, shorter downtimes: these days system and machine management that ensures the optimal use of resources is a critical factor in the economic success of a company. Sensor technology, too, is an indispensable part of this success in the world of automation.

High quality for smooth processes

Optimum performance and maximum reliability: our comprehensive portfolio of sensors combines these important core qualities and ensures smooth and efficient production sequences.

The full range

From the position sensor SMAT to pressure sensing with the pressure sensor SPAN and flow sensing with the flow sensor SFAH, our product portfolio covers the full range of classic sensor tasks for pneumatics. In addition, Festo offers sensors such as the sensor that have been developed for precise and reliable contact sensing and special tasks. The new electronic proximity switch SDBT-MSX is the first proximity sensor with automatic switching point adjustment.

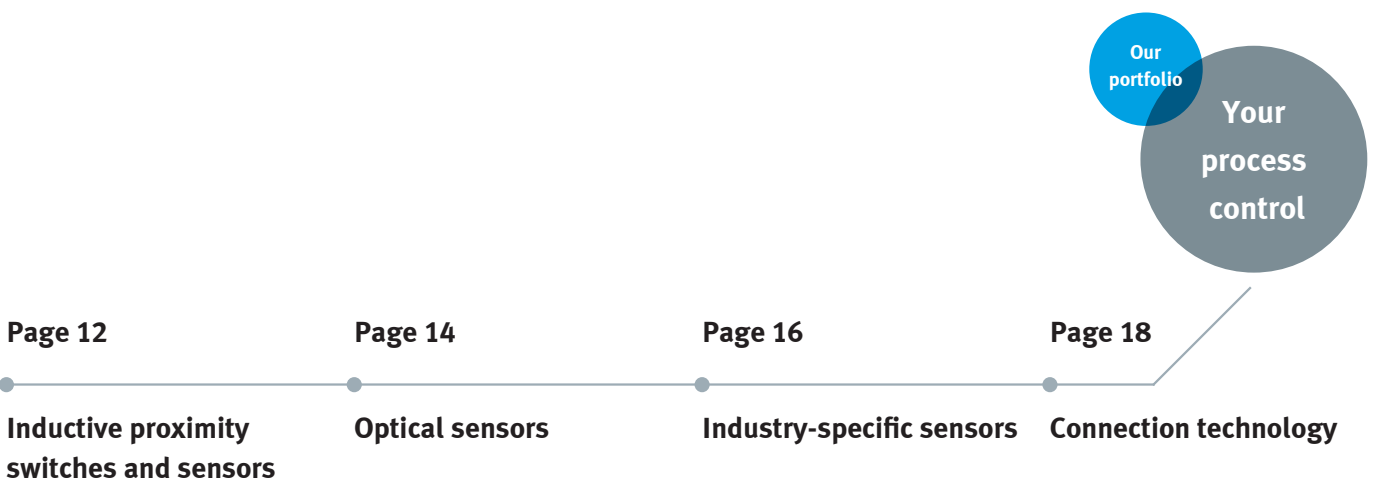

Proximity sensors

Proximity sensors for pneumatic drives form the starting point for the sensor range from Festo – with good cause. These optimally coordinated sensors form a stable and successful platform for new variants and completely new functionalities.

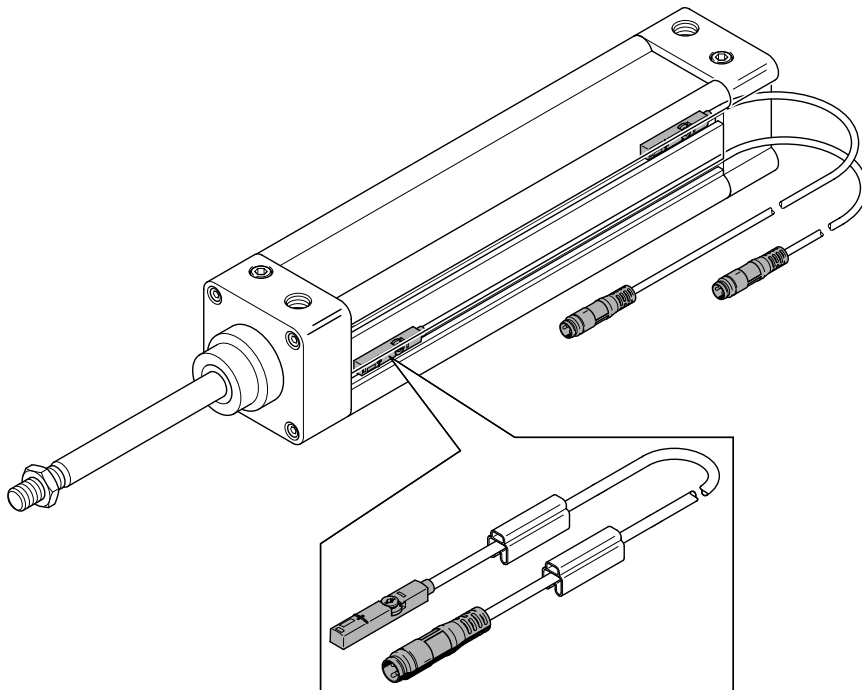

Proximity sensors for every requirement

Proximity sensors from Festo come in a huge range of variants and are ready for practically everything, regardless of what the environment or task demands. Our range even includes suitable mounting accessories.

Here are some examples:

- ATEX
- 230 V
- Safety
- Welding areas
- Cooling lubricants
- Acids and alkali
- Max. temperature 120 °C
- Min. temperature –40 °C
- Potential-free contacts
- Short design for grippers
- Direct plug connection on switch housing
- Food industry

Have you not found what you were looking for? Just ask us!



Electronic proximity switch SDBT-MSX

First proximity switch with auto teach-in! Reliable sensing solution for all drives with T-slot

- Quick and easy to mount without having to search for switching points
- Can be mounted without accessories (power supply)
- Reliable teach-in of the switching position under load during operation
- Programmable switching output: PNP, NPN, N/C contact, N/O contact, switching window range: 2 ... 15 mm
- Electrical connection: M8, open end
- Operating voltage: 10 ... 30 V DC



Electronic proximity switch SMT-8M-A

Reliable sensing solution for all drives with T-slot

- Switching outputs: PNP, NPN, contactless 2-wire
- Switching element function: N/C contact, N/O contact
- Electrical connection: M8, M12, open end
- Operating voltage: 5 ... 30 V DC



Electronic proximity switch SMT-10M

Reliable sensing solution for all drives with C-slot

- Switching outputs: PNP, NPN, contactless 2-wire
- Switching element function: N/O contact
- Electrical connection: M8, M12, open end
- Operating voltage: 5 ... 30 V DC

Position transmitters

Position transmitters provide an analogue, displacement-proportional output signal in the sensing range. The contactless measuring principle ensures wear-resistant sensing, which is a particular advantage in harsh environments.

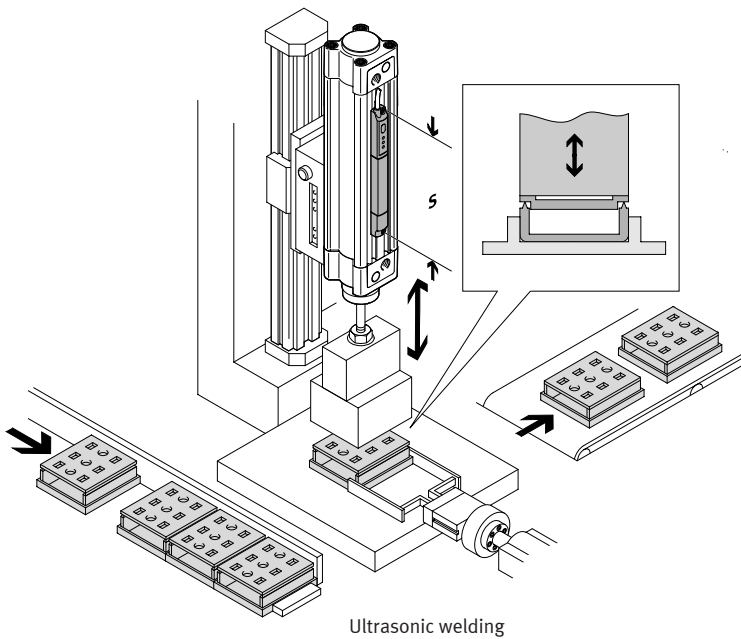

As a consistent further development of the binary proximity sensor, position sensors enable a multitude of new application areas when combined with pneumatic cylinders:

- Quality inspection
- Ultrasonic welding
- Process control during sheet manufacture or during wear monitoring
- Object sensing during pressing or clamping
- Object sensing when recording positions, when changing products or when quality-sorting parts

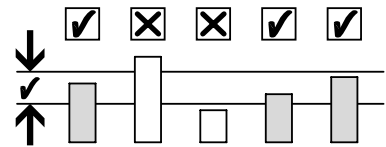
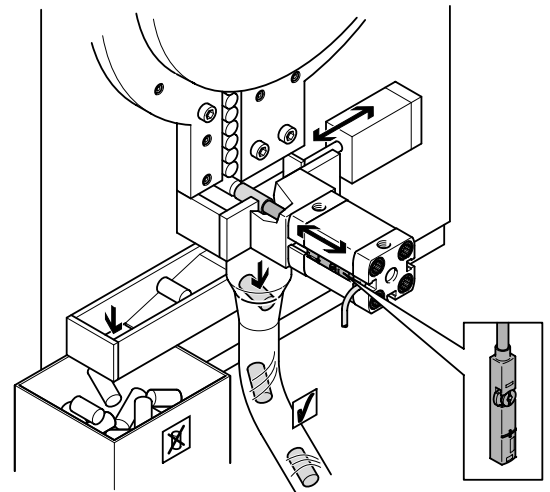

Quality inspection



 IO-Link

Position transmitter SDAT-MHS

The universal transmitter solution. With three options for signal evaluation: classic analogue, programmable switching output or programmable IO-Link output.

Programming options: proximity switch, window comparator, hysteresis comparator. The sensing ranges of the transmitter are perfectly tailored to the standard strokes of Festo cylinders.

- Sensing range: 50, 80, 100, 125, 150 mm
- Analogue output 0 ... 10 V or 4 ... 20 mA
- Programmable IO-Link/switching output
- Repetition accuracy: 0.1 mm



Position transmitter SMAT-8M

As a position transmitter that is the size of a proximity sensor, it is designed for all applications where space is restricted. Its compact design opens up new

areas of application, particularly for compact cylinders and grippers. The piston position is indicated by an analogue voltage signal.

- Sensing range: up to 40 mm
- Analogue output: 0 ... 10 V
- Repetition accuracy: 0.2 mm



 IO-Link

Position sensor SDAS-MHS

Two functions in one device and still no larger than a proximity sensor: position transmitter with IO-Link output and programmable proximity sensor

Programming options: Binary switching outputs: switching point, PNP, NPN, IO-Link output: proximity sensor, window comparator, hysteresis comparator

- Sensing range typically up to 40 mm
- Programmable IO-Link/switching output
- Programmable switching output
- Repetition accuracy: 0.2 mm

Pressure and vacuum sensors

Pressure and vacuum sensors expand the application range of systems, provide greater process reliability and offer the option of remote maintenance and monitoring. They are also easy and quick to use thanks to the standardised control and display concept shared by all Festo pressure sensors.

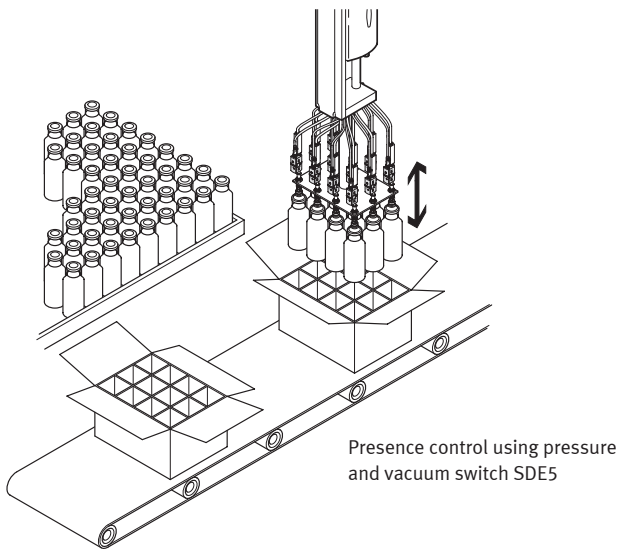

Presence control using pressure and vacuum switch SDE5

Integrated in a service unit, pressure sensor SPAU monitors the pressure range

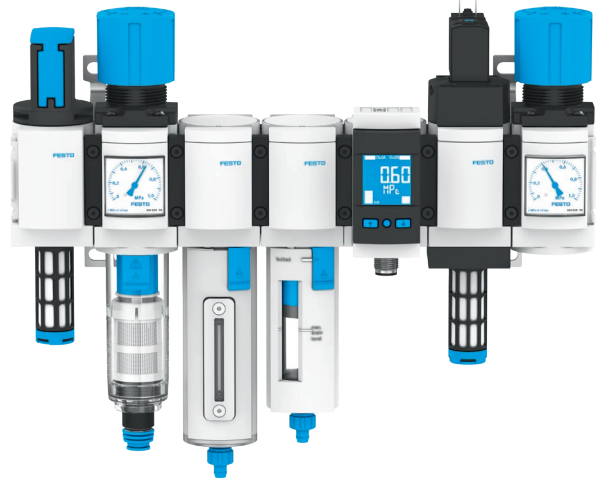

All fluids: pressure sensor SPTW

The SPTW is a universal pressure sensor that is extremely versatile. For air, other gases and fluids.

- 9 pressure measuring ranges from $-1 \dots +1$ bar to $0 \dots +100$ bar
- $4 \dots 20$ mA or $0 \dots 10$ V analogue output



Reliably monitors the pressure of liquids and gases: pressure sensor SPAU

For hydraulics and pneumatics: the compact SPAU measures in 9 measuring ranges from $-1 \dots 1$ and $0 \dots 100$ bar. Suitable for all

media such as water, cooling agents or gases which do not corrode the stainless steel housing and the measuring element (316L or 13-8PH).

- Four-digit display for quick, intuitive configuration of the outputs
- Ideal reading/operation at all times: housing rotates 320° , display at 45° angle
- Switching outputs 2xPNP, 2xNPN, $0 \dots 10$ V, $4 \dots 20$ mA



Price-optimised, modular system: pressure and vacuum switch SDE5

The cost-effective alternative for simple, quick pressure control. It is as effective for sensing compressed air as it is for regulator, vacuum and object detection via back pressure.

- Selectable output functions
- Minimal assembly times thanks to QS connections and M8 connectors

- Quick switching-point adjustment at the touch of a button
- Measuring ranges: $0 \dots 1$, $-1 \dots 1$, $0 \dots 2$, $0 \dots 6$, $0 \dots 10$ bar
- Analogue output $0 \dots 10$ V



Small and simple, but flexible too: pressure transmitter SPTE

Versatile mounting options and stripped down to the basics for pressure or vacuum monitoring on valves and cylinders.

The compact size and minimal weight are ideal, especially for tight installation spaces with high component density.

- Flexible: 3 attachment concepts for fast, low-cost mounting
- Simple: click-mounting and dismantling without tools
- Compact: 8-bracket wall mount for manifold assembly



IO-Link

Extremely small, extremely light, extremely convenient: pressure transmitter SPAE

Monitors the pressure level of filtered compressed air from -1 ... 0 and 0 ... 10 bar. Ideal for vacuum monitoring during pick and place or for pressure

monitoring in pneumatic applications. Flexible and simple mounting with flange, with push-in sleeve or as an inline solution, as well as with tried-and-tested adapters and wall brackets.

- Grid dimension 10 mm – the world's smallest pressure sensor with display
- Very light – ideal for high dynamic response
- Easy to read, convenient and intuitive to operate



IO-Link

The pressure sensors SPAN and SPAN-B: extremely compact and versatile

The attractively priced pressure sensor SPAN is amazingly flexible thanks to switchable electrical outputs and a very wide range of options for pressure measuring ranges and pneumatic connections.

- Compact design 30 x 30 mm
- Pressure and vacuum
- L1 plug for fast commissioning
- Switching outputs (PNP/NPN, NO/NC)
- Analogue outputs (0 ... 10 V, 1 ... 5 V, 4 ... 20 mA)
- Configurable red surround for the entire display

Note:
The SPAN-B variant offers an attractively priced standard product without IO-Link or analogue outputs.



IO-Link

Optimal configuration thanks to unique connection flexibility: pressure sensor SPAU

The sensor for pressure measurement, pressure monitoring and pressure sensing that enables all pressure values to be checked at a glance. IO-Link mode enables

remote maintenance and parameterisation, as well as simple sensor replacement.

- Flexible connection concept
- Quick and easy mounting and commissioning

- Visual pressure status indicator
- One sensor for all controllers



Space-optimised: pressure and vacuum sensor SDE3

Designed for sensing relative and differential pressure – optionally with two independent pressure inputs and a two-colour LCD display in one unit.

- Intuitive prompting and fast teach-in option
- Alphanumerical pressure display for dynamic processes via bar chart
- Space-optimised

- Extremely fast H-rail and front panel mounting
- Code lock for preventing unauthorised changes

Flow sensors

By monitoring the flow, a simplified diagnostic and condition monitoring process can be implemented. A change in the flow rate is often an indication that problems are likely to occur.

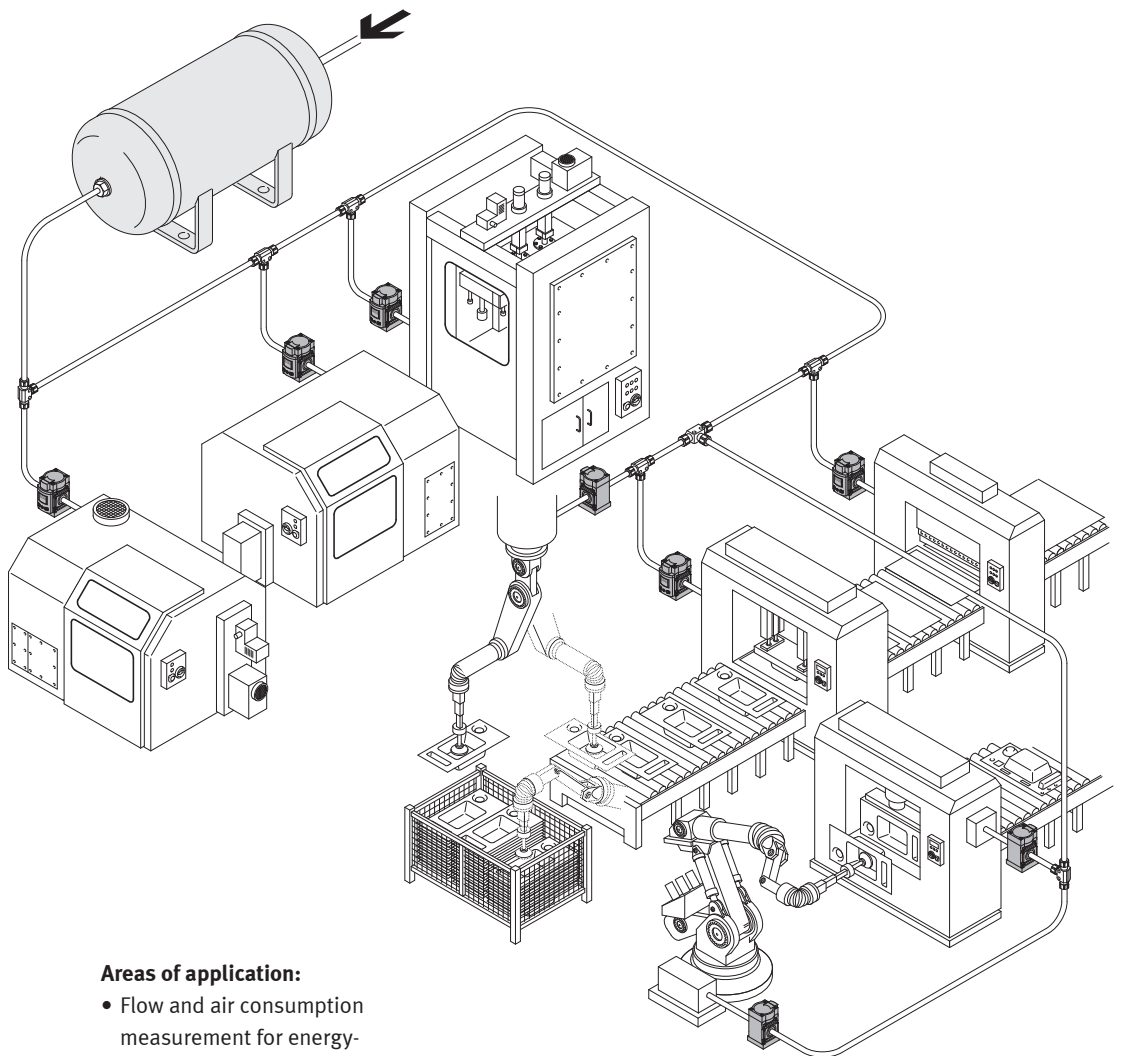

Areas of application:

- Flow and air consumption measurement for energy-efficient sensing
- Leakage monitoring
- Sensing for picking up very small parts (extra small vacuum suction nozzles)
- Presence checking
- Leak tightness testing



IO-Link

Compact: the SFAH monitors the flow rate of compressed air and non-corrosive gases

Many industry sectors will appreciate the flexibility it offers in terms of its compact design (20 x 58 mm), numerous installation options and space-saving adjustable QS elbow connections.

- Switchable electrical outputs
- 8 flow rate measuring ranges from 0.002 l/min ... 200 l/min
- Large operating pressure range -0.9 ... +10 bar

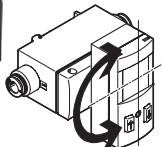

IO-Link

Impressive, simple, reliable: flow sensors SFAB

Our new flow sensors, featuring an attractive display and control concept, are extremely impressive when it comes to flow monitoring, leakage detection and leak tightness testing of end products.

- Monitoring using the teach-in function or by entering values
- 5 flow rate measuring ranges from 0.1 ... 10 l/min. to 10 ... 1000 l/min.
- Mass and volumetric flow rates are displayed in the usual measurement units
- Switching output with adjustable volume capacity
- Optional security code can be freely selected (4-digit code)
- The analogue output needs to be scaled in line with the measuring range required for the application
- Offset compensation is possible
- Min./max. value memory



Compact, yet capable of high flow rates: flow sensors SFAM

The SFAM can be used as a stand-alone device or in combination with MS series service units. A large and bright display provides flow and consumption information,

threshold values and convenient switching point adjustment.

- Switching in line with 3 standard conditions (DIN 1343, ISO 2533, ISO 6358)
- Flexible installation thanks to the compact design
- Unidirectional flow sensor with display: choice of left or right
- Flow ranges: 1000, 3000, 5000, 10000, 15000 l/min
- A high dynamic response of 1:100 offers an extensive measuring range with specific accuracy



IO-Link

Easy monitoring of liquid media with the flow sensor SFAW

The SFAW measures the flow rate, the consumption and the temperature of liquid media within the two measuring ranges. Its simple operation and the easy-to-read display make the SFAW very process reliable.

- 1.8 ... 32 l/min and 5 ... 100 l/min.
- Uniquely flexible connection concept
- Easy sensor replacement without tools
- IO-Link 1.1
- A great view: the display can be rotated 340°



The flow transmitter SFTE is suitable for monitoring small flow rates.

The non-linear sensor signal is output as an analogue voltage signal. This signal can optionally be processed, for example by a controller or a signal converter.

- Pick and place of extremely small workpieces (large signal swing)
- Fast (rise time: 3 ms)
- Compact and lightweight
- 4 variants (1 ... 10 l/min.)

Inductive proximity switches and sensors

The sensors in the series SIE... keep a close eye on all metals.

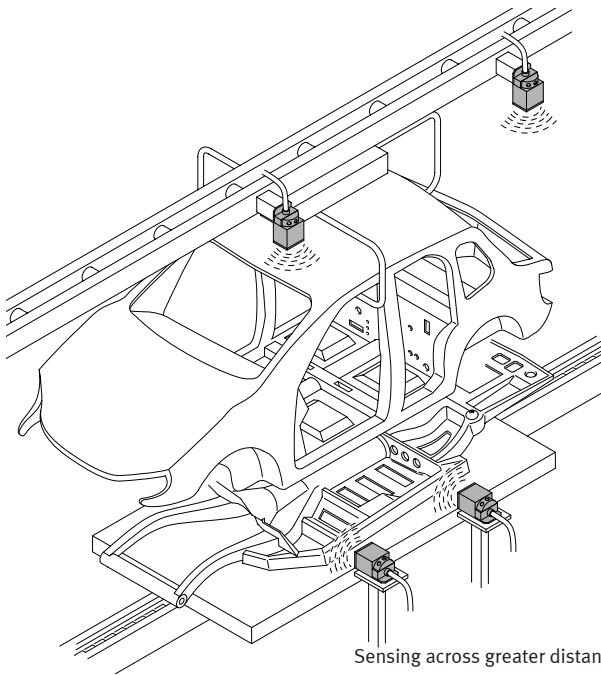

Sensing across greater distances:
inductive proximity sensor SIEF-Q40

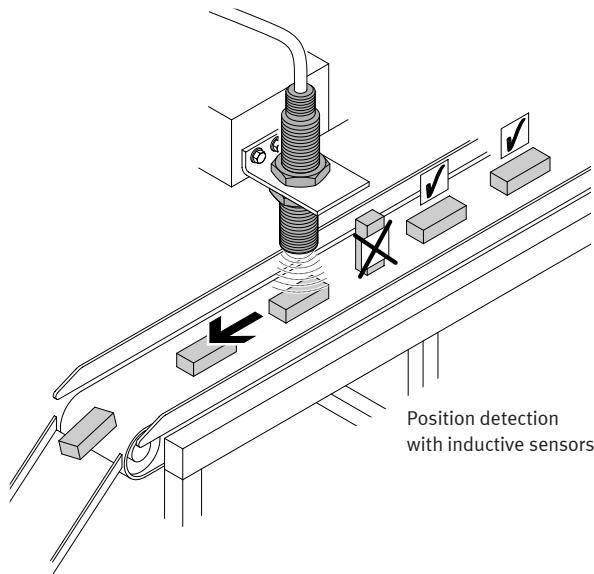

Position detection
with inductive sensors

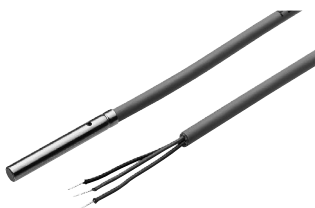

Standard inductive proximity sensors SIE...

Standardised, low cost, reliable, simple – suitable for a wide range of different applications.

- Diameters from 3 mm to M30
- With cable or plug
- N/C or N/O contact
- Flush or non-flush
- High degree of protection IP67

- Direct voltage versions in 3-wire connection method, PNP and NPN
- LED for switching status indication
- Standard-compliant external design for easy replacement of existing solutions



Polyamide inductive proximity switches SIEN/SIED...-PA

The ultimate cost-effective solution for sensing metal objects.

- Approved for the food and packaging industry, can also be used in the chemical industry
- Sturdy thanks to the high degree of protection IP65/IP67

- Standard sizes: M12, M18, M30
- Economical thanks to optimal price/performance ratio



250% faster: factor 1 inductive proximity switch SIEF

The perfect combination of new features – for the most reliable and easy-to-use sensor ever.

- Factor 1, identical sensing distances for a wide range of different metals

- Significantly higher sensing distance compared to standard switches
- Insensitive to external DC and AC magnetic fields



Square: sensors SIES (special design)

Square designs in different sizes now expand the range of cylindrical sensors.

- Thanks to their design, these versions can be mounted directly and are thus extremely space-saving



Inductive sensor in stainless steel housing SIEH-... -CR

Sturdy due to the completely closed stainless steel housing, including the active surface.

- Full metal housing V2A-1.4305-AISI303
- For demanding mechanical requirements
- Pressure resistance

- Large sensing distances (also for other metals)
- M12, M18, (NO, PNP, NPN plug or cable)



Innovative: inductive proximity sensor SIES-8M

Ideal for sensing intermediate and end positions of electric drives. The only inductive sensor for T-slots with patented status display using two LEDs.

- Tried-and-tested mounting technology similar to proximity sensors
- Quick positioning and simple mounting using clamping technology
- Perfect visibility, regardless of the side from which it is approached

- Repetition accuracy $\leq \pm 0.05$ mm
- Power supply 10 ... 30 V
- Switching distance 1.5 mm
- As per EN 60947
- Flush mounting
- Operating temperature $-25 \dots +70$ °C

Optical sensors

Thanks to their optical measuring method, the sensor series SO... covers a wide range of different functions, from detecting colour and miniature components through to laser distance sensing.

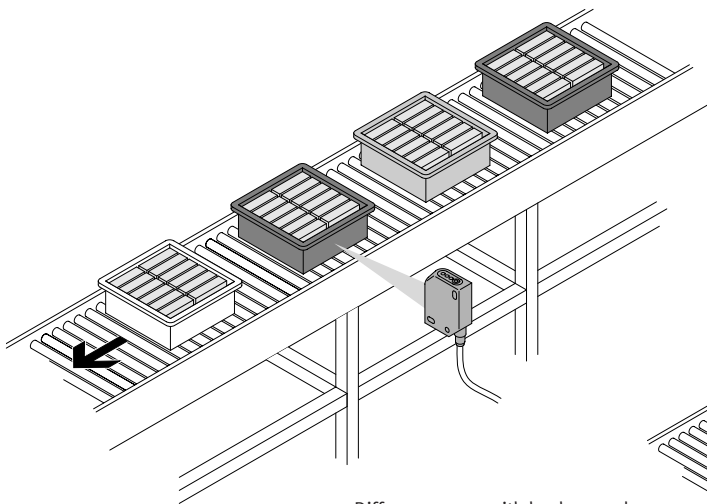

Diffuse sensors with background illumination can sense objects irrespective of the surface and colour.

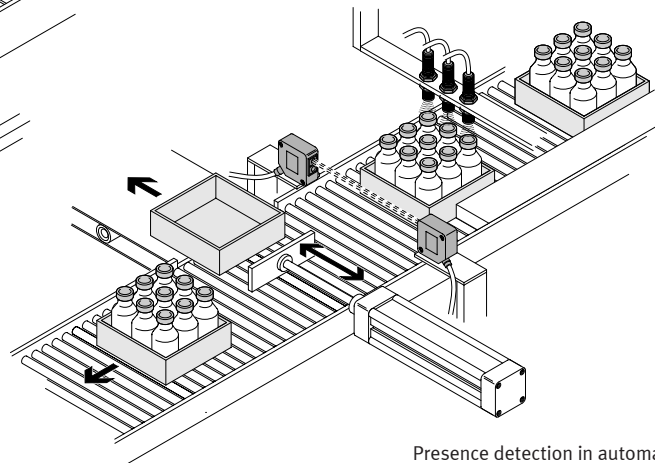

Presence detection in automation technology



Small yet accurate: fibre-optic cables and fibre-optic units SOE4

These provide precise and space-saving position detection on very complex and compact machines, particularly in the electronics and light assembly industries. They can also detect small workpieces (any material) at great distances or high temperatures.

- Highly flexible in use thanks to a choice of three fibre-optic units: with or without display, with display and analogue output
- Fast and reliable set-up using simple teach-in method
- Flexible switching between four operating modes: standard, fine mode, fast mode, long-distance mode
- Up to four fibre optic units mounted next to each other work in synch to avoid mutual interference



 IO-Link

Reliable and efficient: fork light barriers SOOF-P and SOOF-M

Easy to install and adjust because the emitter and the receiver are in a single housing. Conventional metal version or innovative polymer variant with a status display which is visible from all sides.

SOOF-M is now available with IO-Link as a standard feature.

- Degree of protection IP67
- Fork widths: 30, 50, 80 and 120 mm
- Numerous mounting types
- Good visibility thanks to red light
- Adjustment via teach-in (SOOF-P) or potentiometer (SOOF-M)
- Accurate, with high resolution and repetition accuracy



Engineering in record time with the optoelectronic sensors SOOD

From background suppression to through-beam sensing, this complete solution makes it possible to achieve an unprecedented level of flexibility and versatility.

- Easy to operate
- Quick to commission
- Reliable and stable detection
- Low complexity, PNP and NPN in one device



 **IO-Link**

Compact and flexible: optoelectronic sensors SOOE

With the SOOE you get all the optical functions for object sensing in an identical sensor housing. From through-beam sensing to distance sensing, you benefit from the most innovative technologies and at the same time reduce device variety thanks to universal assembly.

- Precise object detection at a distance of 1 mm to 20 m
- Intelligent analysis of the distance information
- High insensitivity towards extraneous light
- Reliable and stable detection IO-Link®
- Low complexity, PNP and NPN in one device



Minimal size: colour sensor SOEC-RT-Q50

Using only a white light source, and with a standard housing, the SOEC-RT-Q50 can locate objects anywhere within its entire operating range. Featuring 5 definable limit values the sensor can be optimally tuned to the colour of the test object.

- The sensor can quickly and easily learn to recognise new colours of objects via its “teach-in” function.
- 3 independent channels with teach-in capability
- Switching frequency 500 Hz



Standard design: optoelectronic sensors SOEG-...-M12/M18/M18W

Standard-compliant design to make exchanging sensors easy.

Numerous variants such as diffuse sensors, sensors with background suppression, retro-reflective and through-beam sensors, etc.

- Diameters: M12, M18 and M18W (with lateral light emission)
- With cable or plug
- With PNP or NPN output

Industry-specific sensors

All kinds of industries rely on the excellent products and services from Festo. This leads to a first-class partnership and the creation of application-optimised products in line with the needs and tasks of customers which will increase your productivity and process reliability. And it enables us to offer the automotive industry, the food industry and many other sectors everything from a single source.

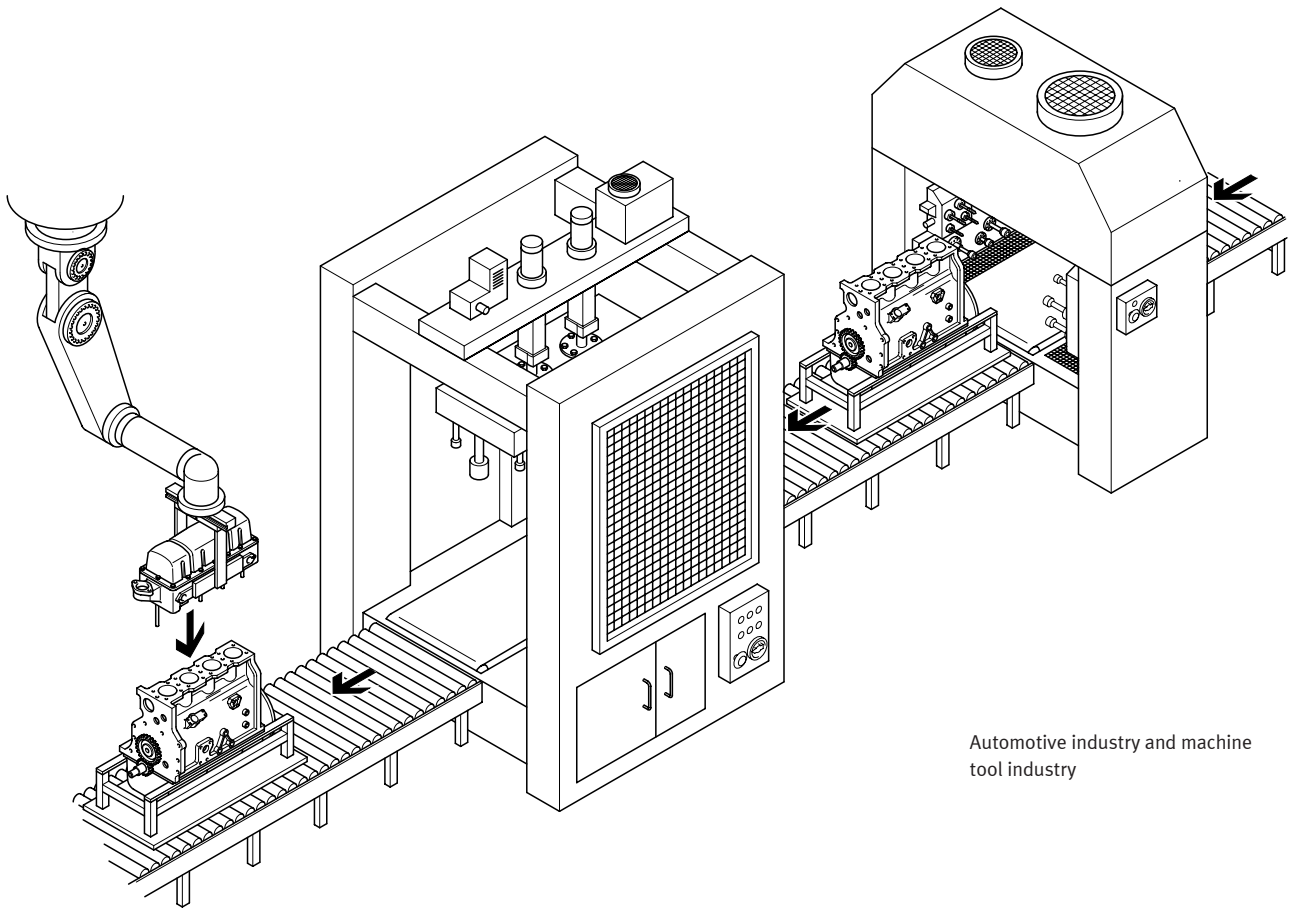

Automotive industry and machine tool industry



IO-Link

**Precise and reliable:
air gap sensor SOPA**

The reliable, attractively priced compact solution for high precision contact monitoring in the μm range, for example when machining engine parts – also available with IO-Link.

Fully equipped with a controller module, compressed air regulation, measurement air switch-off, air jet function and up to 4 measuring modules. Added bonus: up to 4 air gap sensors can be configured on a modular basis and pneumatically linked.

- Detection of 2 different distances with distance correlation is possible
- Measuring range: 20 ... 200 μm
- Operating pressure: 4 ... 7 bar
- Switching value: $\pm 2.5 \mu\text{m}$
- Analogue output: 1 ... 5 V, 0 ... 10 V or 4 ... 20 mA
- Switching outputs: 2 PNP, 2 NPN, PNP/NPN switchable
- Switching function freely programmable
- IP65 degree of protection

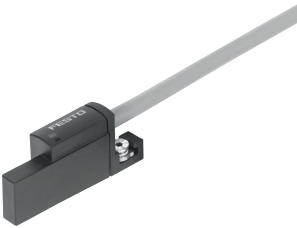

**Absolutely safe welding:
welding field immune proximity sensor SDBT-BSW**

Ideal for hinge cylinders DW/DWA/DWB, the SDBT-BSW is unique as it is welding field immune for medium frequency welding at 1,000 Hz MFDC. And it functions reliably with 50 Hz AC welding as well.

It does its job in the automotive industry extremely reliably and indicates the mid or end position of the piston in binary mode.

- Standardised package solution, reliable both mechanically and electrically
- Sensor and cylinder DW/DWA/DWB, ADN or DSBC from a single source
- Immune to magnetic fields generated by typical welding applications
- Cable and housing materials resistant to welding spatter



**Capable of high loads:
proximity switch CRSMT-8M**

The CRSMT-8M is extremely durable whether used in the food industry or in harsh ambient conditions. The range includes mounting components for Clean

Design drives with a sensor rail – quick, easy and stable to install.

- Resistant to acids, alkali and cooling lubricants
- Degree of protection: IP65, IP68 and IP 69k
- Cable length up to 10 m
- Connection technology: M8, M12, open end

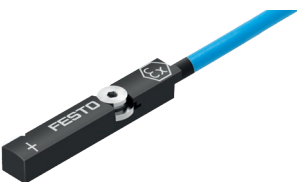

**The universal solution for ATEX applications:
proximity switch SDBT-MS...EX6**

- Suitable for ATEX zones 0, 1, 2, 20, 21 and 22, as well as equipment categories 1GD, 2GD and 3GD.
- Certified to IECEx, ATEX, Inmetro, CCC Ex and KCC

- NAMUR output, connection to an isolation amplifier is required
- Electrical connection: open end

Connection technology

Fits and functions smoothly: the sensor portfolio from Festo. Optimally harmonised with each other, the modular cable system NEBU connects field devices and controllers – connection problems are a thing of the past.



Multiple combinations: modular system for connecting cables NEBU

Find the ideal connection quickly: the NEBU modular system for connecting cables provides unlimited combination possibilities including sockets, various cable lengths and qualities, and

plugs. Low cost, reliable and flexible. Matched to all devices with M8 and M12 plugs such as proximity sensors, position transmitters, pressure and flow sensors, optical and inductive sensors,

as well as individual valves. There is a free choice of cable lengths between 0.1 and 30 m.



Saves space and costs by reducing components: sensor/actuator distributor NEDY

The sensor/actuator distributor NEDY creates connections between two field devices and double M8/M12 input/outputs on decentralised I/O modules,

with much less installation effort. Thanks to the reduced number of components, NEDY also saves space and costs, making it ideal for the automation platform CPX, for example.

- Installation-optimised distribution in an instant
- Suitable for use with energy chains and robots
- Protects PUN tubes because it is free of phosphoric acid ester



Flexible in use: the NEBB connecting cables are an extremely efficient cabling solution for connecting your systems.

The cost-optimised NEBB with a cable sheath made of high-quality PVC offers over 30 variants, high

degrees of protection IP65, 68 and 69k, as well as corrosion-resistant, gold-plated pin contacts. The 3-, 4- or 5-pin NEBB is available in lengths of 2.5, 5 or 10 m, with a minimum order quantity of 1.

- Resistant to acids, bases and disinfectants
- Degree of protection IP65, 68, 69k
- Easy to assemble, easy to strip
- ATEX zone 2, 22



 IO-Link

Compact, precise and easy to read: signal converter SCDN

The SCDN has a wide variety of possible applications. The conversion of analogue signals into digital switching signals or IO-Link® signals does away with the

need for analogue inputs on controllers. The fast and decentralised signal processing significantly reduces the controller's workload.

- Tamper-proof
- Good readability, colour change to red
- Compact design 30 x 30 mm



Productivity

Maximum productivity is a question of ambition

Do you share this attitude? We will be glad to help you achieve this goal – through our four outstanding qualities:

- Security • Efficiency • Simplicity • Competency

We are the engineers of productivity.

Discover new dimensions for your company:

→ www.festo.com/whyfesto