

PICtail™ Plus Expansion Board Information Sheet

Overview

The PICtail™ Plus Expansion Board extends the capabilities of either the legacy Explorer 16 Development Board or the Explorer 16/32 Development Board (www.microchip.com/Explorer1632). When used with either board, the PICtail Plus Expansion Board provides either forward or backwards compatibility, as necessary, for attaching both mikroBUSTM and PICtail Plus (vertical card edge) based hardware daughter boards.

The legacy Explorer 16 board does not have any mikroBUS interface connectors. Attachment of up to two mikroBUS daughter boards is possible, however, when used with the PICtail Plus Expansion Board. The pinout for the two mikroBUS interfaces is effectively the same as the Explorer 16/32 Development Board mikroBUS interfaces, allowing for firmware compatibility between both platforms.

The Explorer 16/32 Development Board does not have a vertical PICtail Plus board connector (instead, using the area for female I/O pin access headers), but attachment of existing vertical card edge-based PICtail Plus Daughter Boards is possible through the use of the PICtail Plus Expansion Board.

The PICtail Plus Expansion Board also has a small prototyping area, and serves as a pass through for signals, allowing for the attachment of additional horizontally connected PICtail Plus Daughter Boards.

Americas

Atlanta - 678-957-9614
Austin - 512-257-3370
Boston - 774-760-0087
Chicago - 630-285-0071
Dallas - 972-818-7423
Detroit - 248-848-4000
Houston - 281-894-5983
Indianapolis - 317-773-8323
Los Angeles - 949-462-9523
New York - 631-435-6000
Phoenix - 480-792-7200
Raleigh - 919-844-7510
San Jose - 408-735-9110
Toronto - 905-695-1980

Europe

Austria - Wels - 43-7242-2244-39
Denmark - Copenhagen - 45-4450-2828
Finland - Espoo - 358-9-4520-820
France - Paris - 33-1-69-53-63-20
Germany - Garching - 49-8931-9700
Germany - Haan - 49-2129-3766400
Germany - Heilbronn - 49-7131-67-3636
Germany - Karlsruhe - 49-721-625370
Germany - Munich - 49-89-627-144-0
Germany - Rosenheim - 49-8031-354-560
Israel - Ra'anana - 972-9-744-7705
Italy - Milan - 39-0331-742611
Italy - Padova - 39-049-7625286
Netherlands - Drunen - 31-416-690399
Norway - Trondheim - 47-7289-7561
Poland - Warsaw - 48-22-3325737
Romania - Bucharest - 40-21-407-87-50
Spain - Madrid - 34-91-708-08-90
Sweden - Gothenberg - 46-31-704-60-40
Sweden - Stockholm - 46-8-5090-4654
UK - Wokingham - 44-118-921-5800

Asia/Pacific

Australia - Sydney - 61-2-9868-6733
China - Beijing - 86-10-8569-7000
China - Chengdu - 86-28-8665-5511
China - Chongqing - 86-23-8980-9588
China - Dongguan - 86-769-8702-9880
China - Guangzhou - 86-20-8755-8029
China - Hangzhou - 86-571-8792-8115
China - Hong Kong SAR - 852-2943-5100
China - Nanjing - 86-25-8473-2460
China - Qingdao - 86-532-8502-7355
China - Shanghai - 86-21-3326-8000
China - Shenyang - 86-24-2334-2829
China - Shenzhen - 86-755-8864-2200
China - Suzhou - 86-186-6233-1526
China - Wuhan - 86-27-5980-5300
China - Xiamen - 86-592-2388138
China - Xian - 86-29-8833-7252
China - Zhuhai - 86-756-3210040
India - Bangalore - 91-80-3090-4444
India - New Delhi - 91-11-4160-8631
India - Pune - 91-20-4121-0141
Japan - Osaka - 81-6-6152-7160
Japan - Tokyo - 81-3-6880-3770
Korea - Daegu - 82-53-744-4301
Korea - Seoul - 82-2-554-7200
Malaysia - Kuala Lumpur - 60-3-7651-7906
Malaysia - Penang - 60-4-227-8870
Philippines - Manila - 63-2-634-9065
Singapore - 65-6334-8870
Taiwan - Hsin Chu - 886-3-577-8366
Taiwan - Kaohsiung - 886-7-213-7830
Taiwan - Taipei - 886-2-2508-8600
Thailand - Bangkok - 66-2-694-1351
Vietnam - Ho Chi Minh - 84-28-5448-2100

10/25/17



Microchip Technology Inc. • 2355 West Chandler Blvd. • Chandler, AZ 85224-6199

www.microchip.com

The Microchip name and logo and the Microchip logo are registered trademarks of Microchip Technology Incorporated in the U.S.A. and other countries. PICtail is a trademark of Microchip Technology Incorporated in the U.S.A. and other countries. All other trademarks mentioned herein are property of their respective companies.

© 2017, Microchip Technology Incorporated, Printed in the U.S.A. All Rights Reserved. 11/17

DS50002469C

PICtail™ Plus Expansion Board Information Sheet

Schematics Version 1.0 (Sheet 1 of 2)

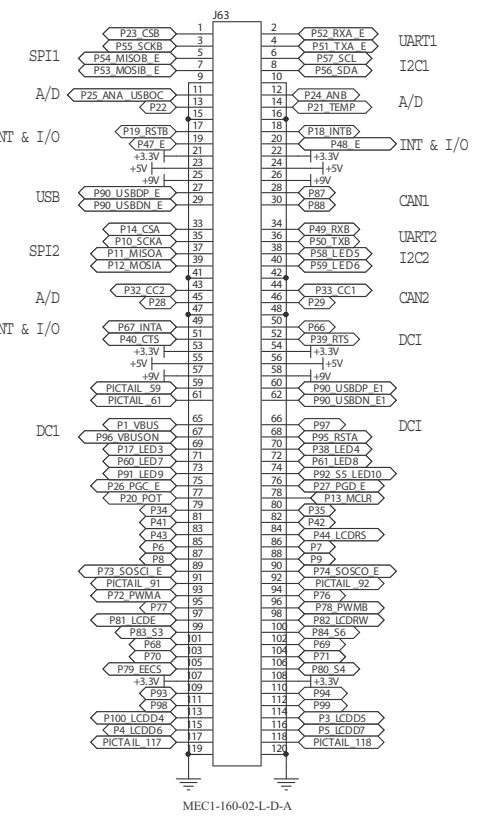
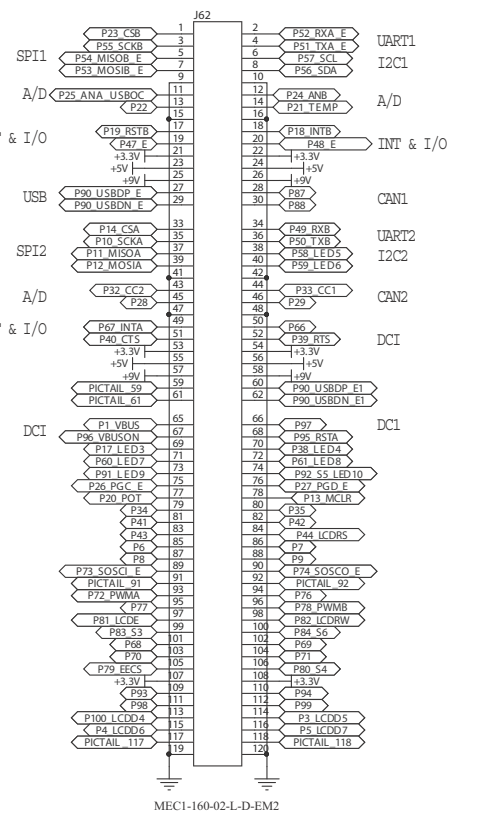
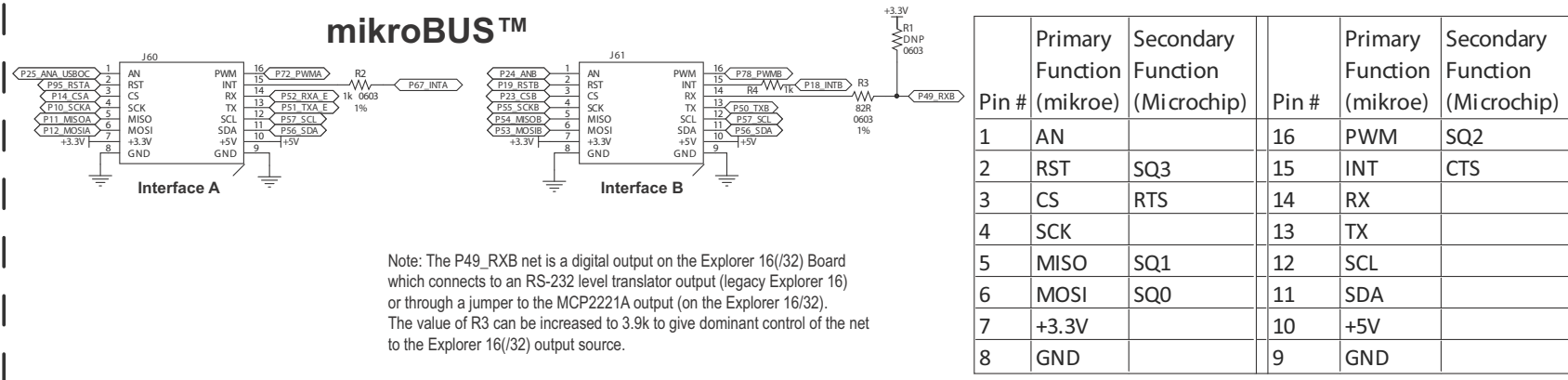

PICtail™ Plus Expansion Board Information Sheet

Schematics Version 1.0 (Sheet 2 of 2)

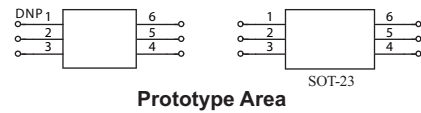
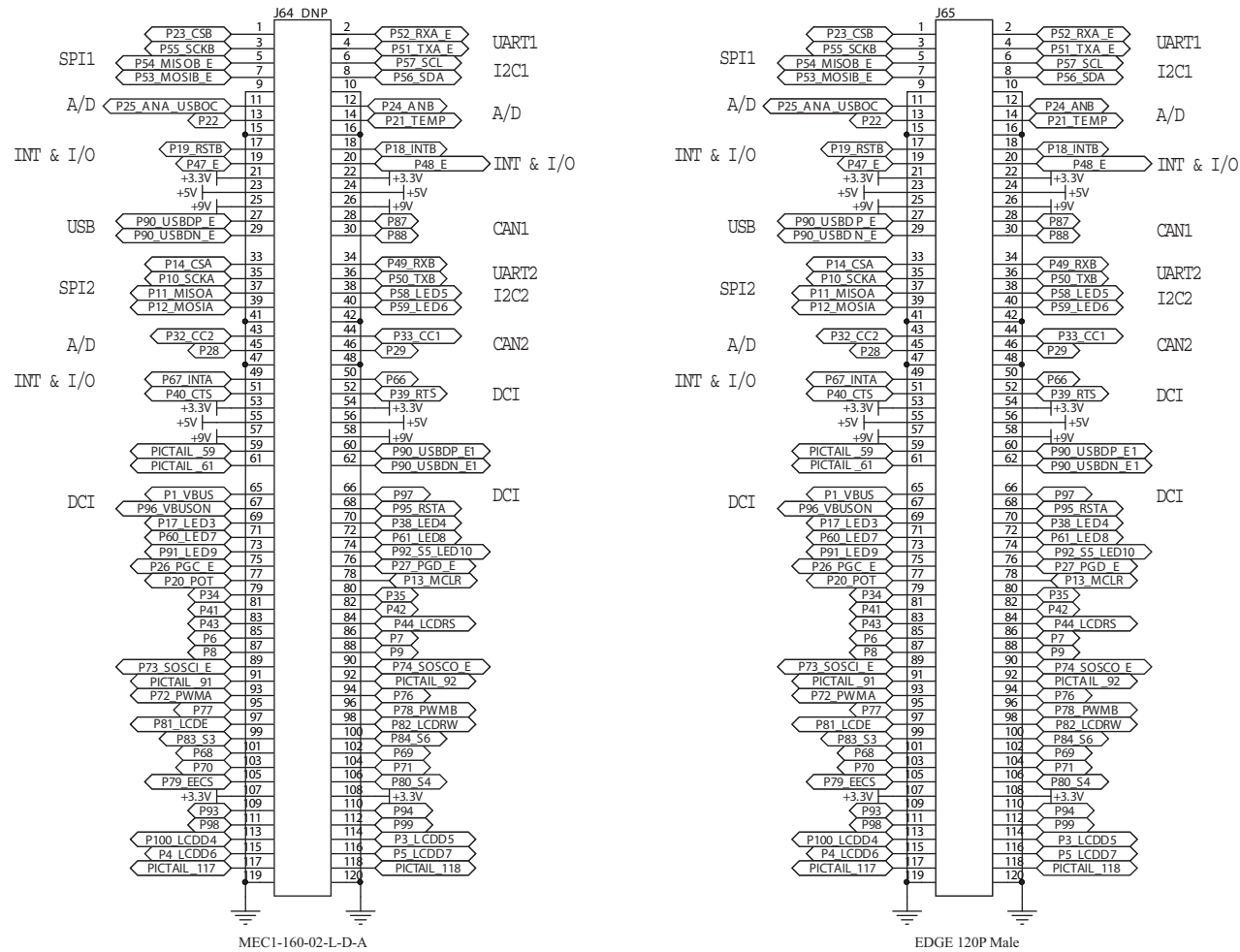

Designed with
Altium
 Altium.com