

# AC axial fans

AC axial fan overview	143
AC axial fans	144



## Technical information

### Product line

The renowned ebm-papst AC fans are used when DC voltage is not available. The AC range of fans is based on experience gained from decades of development activity, millions of units in series production and competence in innovation of a world-wide technological leader.

A wide range of fans for AC operation is presented in this catalogue. In addition to complete device fans, you will also find fans without external housing, providing a particularly economical advantage when the air duct can be integrated in the respective device.

### Variety of sizes

AC fans are available in a variety of sizes with either air exhaust or air intake over struts. Silent running models with sleeve bearings or for extreme ambient conditions; fans with ball bearings are available with plug connection or external leads.

### Shaded-pole or capacitor motors

Fan drives by shaded-pole or capacitor motors, most of which incorporate the world-famous ebm-papst external rotor principle: The fan blades are directly attached to the external rotor of the external rotor motor, thus combining both high performance and profitability.

### Flat built AC fans

ebm-papst also has particularly flat built AC fans with internal rotor motor. Their advantage: quick start to full speed. A plastic impeller and the both smaller and lighter internal rotor motor lead to a lower moment of inertia.

### Bearings

AC fans with sleeve bearings are powered by Class E insulated motors. Fans with ball bearings are equipped with Class B, E or F insulated motors.

### Protection class

All ebm-papst fans conform to the requirements of IP 20. Fans conforming to IP 54 and special types of protection class are also available.

### AC voltage

The line of AC fans for Euro voltage according to IEC 60038 (230 V + 6 %, -10 %) is basically also available for 115 V.

### Frequencies

AC fans can be operated at frequencies of 50 Hz or 60 Hz. However, their technical data then changes accordingly.

### Capacitor

Fans driven by capacitor external motors provide particularly high operating efficiency. Generally, the required operating capacitor is already integrated in the fan housing.

### Overloading

Almost all AC fans are protected against overloading (e.g. due to locked rotor) the drive motors are either impedance protected (marked "Impedance protected", and/or "Z.P.") or are equipped with a thermal switch (marked "Thermally protected" or "Th.P."). The model designation of these fans ends with "S".

# Axial fans for AC operation

## Overview of air performance

Dimension	Series	Air flow	Air flow (m <sup>3</sup> /h)																	Page			
			10	20	30	40	50	60	70	80	90	100	200	300	400	500	600	700	800		900	1000	2000
□ 80 x 38	8000 A	29...57																					144
□ 80 x 38	8000 N	30...61																					145
∅ 76 x 37	8000 TA	23...45																					146
∅ 76 x 37	8000 TV	24...47																					147
□ 92 x 25	3900	31...70																					148
□ 92 x 38	3000	49...89																					149
□ 119 x 25	9900	84...135																					150
□ 119 x 38	4000 N	80...180																					151
□ 119 x 38	4000 Z	100...180																					152
∅ 113 x 37	4600 TA	138...147																					153
∅ 108 x 37	4600 TZ	125...140																					154
□ 127 x 38	5900	150...206																					155
□ 135 x 38	5600	235...270																					156
150 x 172 x 38	7000	330...390																					157
∅ 150 x 55	7800	325...380																					158
∅ 150 x 55	7400	390...445																					159
∅ 172 x 51	6000	375...500																					160
∅ 225 x 80	W**200	450...1030																					161
□ 280 x 80	W2E 250	1865																					162

## Overview of technically feasible designs

Series	Dimension	VDE, UL, CSA	Sleeve bearings/ ball bearings	Speed sensor	Humidity protection IP >= IP54	Salt spray fog protection	Page
8000 A	80 x 80 x 38	yes	□/■	-	••••		144
8000 N	80 x 80 x 38	yes	□/■	-	••••		145
8000 TA	76 ∅ x 37	yes	□/■	-	••••		146
8000 TV	76 ∅ x 37	yes	□/■	-	••••		147
3900	92 x 92 x 25	yes	□/■	-	• - - -		148
3000	92 x 92 x 38	yes	□/■	-	••••		149
9900	119 x 119 x 25	yes	□/■	-	• - - -		150
4000 N	119 x 119 x 38	yes	□/■	•	••••		151
4000 Z	119 x 119 x 38	yes	□/■	•	••••		152
4600 TA	113 ∅ x 37	yes	□/■	-	••••		153
4600 TZ	108 ∅ x 37	yes	□/■	-	••••		154
5900	127 x 127 x 38	yes	□/■	-	• - - -		155
5600	135 x 135 x 38	yes	■	-	••••		156
7000	150 x 172 x 38	yes	■	-	- - - -		157
7800	150 ∅ x 55	yes	■	•	- - - -		158
7400	150 ∅ x 55	yes	■	-	- - - -		159
6000	172 x 51	yes	■	-	- - - -		160

• available - not yet available □ Sleeve bearings ■ Ball bearings

## Information on pictograms

On the pages of the catalogue and on the following overview pages, the pictograms illustrated below provide information about technically possible special versions in the fan line presented.

Please note that these special versions are not possible for all voltages and speeds, and not in all combinations.

The special versions are designed for specific customers and projects and are not usually available off the shelf.



### Speed signal

The fan uses a separate wire to output information about its speed, and thus about the speed of the rotor. For technical details, please refer to page 110.



### Protection against moisture

Protection for the fan's electronics against moisture and condensation. For technical details, please refer to page 123.



### IP 54

Protection of motor and PCB board against splashed water and humidity. For technical details, please refer to page 123.



### Protection against salt spray fog

Protection of fan against the damaging effects of salt spray fog. For technical details, please refer to page 123.

max. 57 m<sup>3</sup>/h

# AC axial fans

Series 8000 A 80 x 80 x 38 mm

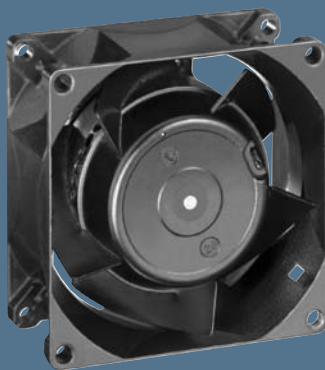

- AC fans with external rotor shaded-pole motor. Impedance protected against overloading.
- Metal fan housing and impeller.
- Air intake over struts. Direction of rotation clockwise, seen on rotor.
- Electrical connection via 2 flat plugs 2.8 x 0.5 mm.
- Fan housing with grounding lug and screw M4 x 8 (TORX).
- Mass: 490 g.
- Optionally available with electrical connection via leads.
- Optionally available with air exhaust over struts and clockwise direction of rotation.
- Please note our new ACmaxx series. With identical mounting dimensions and voltages, this series achieves higher energy efficiency.

Nominal data	Air flow		Nominal voltage	Frequency	Sound pressure level	Sound power level	Sinter sleeve bearings Ball bearings	Power input	Nominal speed	Temperature range	Service life L <sub>10</sub>		Curve
	m <sup>3</sup> /h	CFM									at 40 °C	at T <sub>max</sub>	
Type	m <sup>3</sup> /h	CFM	V	Hz	dB(A)	Bel(A)	□ / ■	Watts	RPM	°C	Hours	Hours	
8880 A	29	17,1	230	50	26	4,1	□	9,0	1 750	-10...+80	60 000 / 25 000		1
8850 A	36	21,2	230	50	31	4,6	□	12,5	2 150	-10...+70	52 500 / 25 000		2
8550 A	48	28,3	230	50	36	5,0	□	12,0	2 700	-10...+70	52 500 / 25 000		3
8556 A	48	28,3	230	50	37	5,1	■	12,0	2 800	-40...+90	52 500 / 15 000		3
8830 A	34	20,0	115	60	29	4,3	□	8,0	1 950	-10...+80	62 500 / 25 000		4
8800 A	45	26,5	115	60	34	4,8	□	11,0	2 500	-10...+70	55 000 / 27 500		5
8500 A	57	33,5	115	60	41	5,5	□	11,0	3 200	-10...+75	55 000 / 25 000		6
8506 A	57	33,5	115	60	42	5,7	■	11,0	3 300	-40...+95	55 000 / 15 000		6

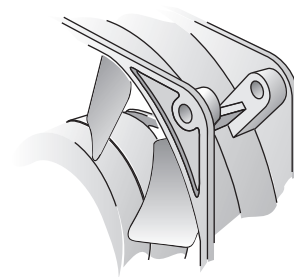

Series 8000 A with reinforced flanges

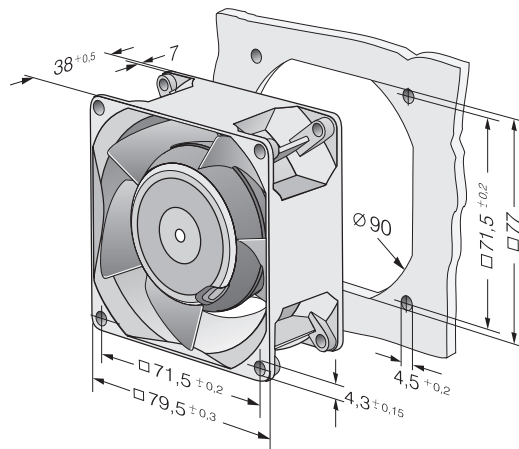
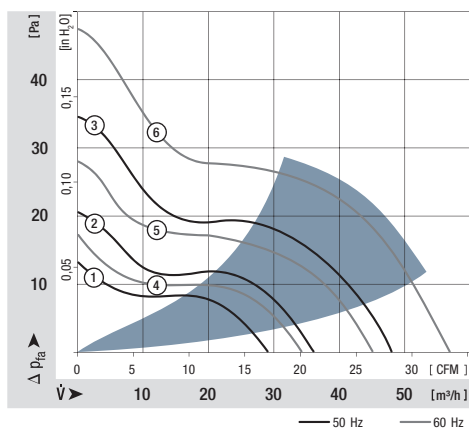

max. 61 m<sup>3</sup>/h

# AC axial fans

Series 8000 N 80 x 80 x 38 mm



- AC fans with external rotor shaded-pole motor. Impedance protected against overloading.
- Metal fan housing and impeller.
- Air exhaust over struts. Direction of rotation clockwise, seen on rotor.
- Electrical connection via 2 leads. Bared and tin-plated.
- Fan housing with grounding lug for screw M4 x 8 (TORX).
- Mass: 490 g.
- Please note our new ACmaxx series. With identical mounting dimensions and voltages, this series achieves higher energy efficiency.

Nominal data		Air flow	Air flow	Nominal voltage	Frequency	Sound pressure level	Sound power level	Sinter sleeve bearings Ball bearings	Power input	Nominal speed	Temperature range	Service life L <sub>10</sub> at 40 °C	at T <sub>max</sub>	Curve
Type		m <sup>3</sup> /h	CFM	V	Hz	dB(A)	Bel(A)	□ / ■	Watts	RPM	°C	Hours	Hours	
8880 N		30	17,7	230	50	18	3,3	□	9,0	1 750	-10...+80	60 000 / 25 000		1
8850 N		37	21,8	230	50	24	3,9	□	12,5	2 150	-10...+70	52 500 / 25 000		2
8550 N		50	29,4	230	50	30	4,4	□	12,0	2 700	-10...+70	52 500 / 25 000		3
8556 N		50	29,4	230	50	31	4,5	■	12,0	2 800	-40...+90	52 500 / 15 000		3
8830 N		36	21,2	115	60	21	3,7	□	8,0	1 950	-10...+80	62 500 / 25 000		4
8800 N		47	27,7	115	60	28	4,3	□	11,0	2 500	-10...+70	55 000 / 27 500		5
8500 N		61	35,9	115	60	34	4,8	□	11,0	3 200	-10...+75	55 000 / 25 000		6
8506 N		61	35,9	115	60	35	5,0	■	11,0	3 300	-40...+95	55 000 / 15 000		6

Fan type				Lead wires	
8830 N	8800 N	8550 N	8500 N	310 mm long	AWG 18, TR 64
8880 N				310 mm long	AWG 18, TR 64
8556 N	8506 N			310 mm long	AWG 22
8850 N				440 mm long	AWG 18, TR 64

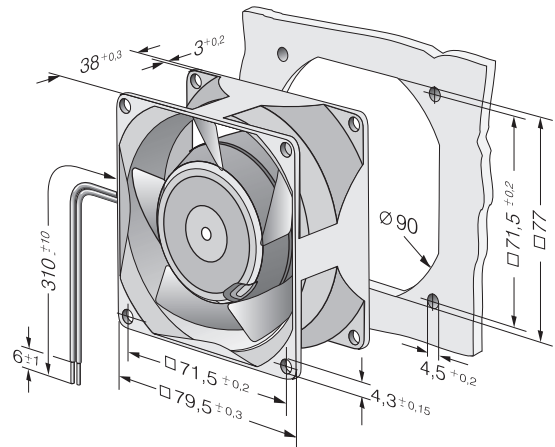
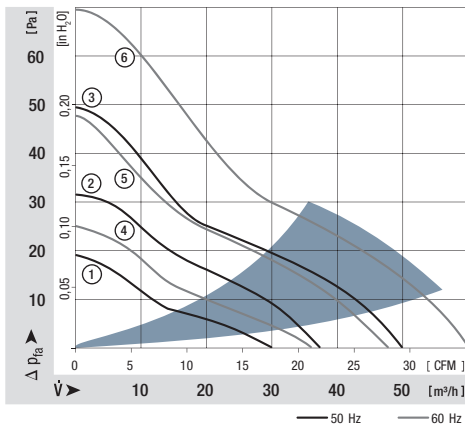

max. 45 m<sup>3</sup>/h

## AC axial fans

Series 8000 TA 76 Ø x 37 mm

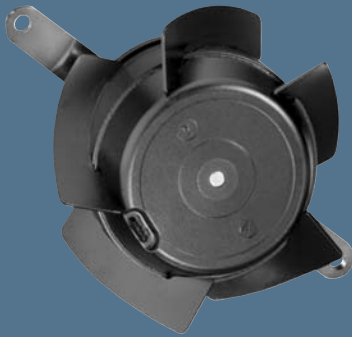

- AC fans with external rotor shaded-pole motor. Impedance protected against overloading.
- Impeller and mounting bracket of metal.
- Air intake over mounting bracket. Direction of rotation clockwise, seen on rotor.
- Electrical connection via 2 leads. Bared and tin-plated.
- Mass: 370 g.
- Please note our new ACmaxx series. With identical mounting dimensions and voltages, this series achieves higher energy efficiency.

Nominal data	Air flow		Nominal voltage	Frequency	Sound pressure level	Sinter sleeve bearings Ball bearings	Power input	Nominal speed	Temperature range	Service life L <sub>10</sub>		Curve
	m <sup>3</sup> /h	CFM								V	Hz	
8880 TA	23	13,5	230	50	15	□	9,0	1 650	-10...+80	60 000 / 25 000		-
8850 TA	30	17,7	230	50	19	□	12,0	2 100	-10...+70	52 500 / 25 000		-
8550 TA	38	22,4	230	50	25	□	12,0	2 650	-10...+70	52 500 / 25 000		-
8556 TA	38	22,4	230	50	26	■	12,0	2 750	-40...+90	52 500 / 15 000		-
8830 TA	26	15,3	115	60	18	□	8,0	1 850	-10...+80	62 500 / 25 000		-
8800 TA	34	20,0	115	60	23	□	11,0	2 450	-10...+70	55 000 / 27 500		-
8500 TA	45	26,5	115	60	30	□	11,0	3 150	-10...+75	55 000 / 25 000		-
8506 TA	45	26,5	115	60	31	■	11,0	3 250	-40...+95	55 000 / 15 000		-

The air flow and noise level of fans without external housing depends on the installation conditions. The stated air flow and noise has been measured with an orifice 76.5 mm Ø at a distance of approx. 17 mm from the mounting bracket. Under exceptionally favourable mounting conditions, the air flow of fan series 8000 A is achievable. The noise in the optimal operating range can only be measured for these fans in a specific application.

Fan type				Lead wires	
8880 TA	8850 TA	8830 TA	8800 TA	325 mm long	AWG 18, TR 64
8550 TA	8500 TA			325 mm long	AWG 18, TR 64
8556 TA	8506 TA			325 mm long	AWG 18

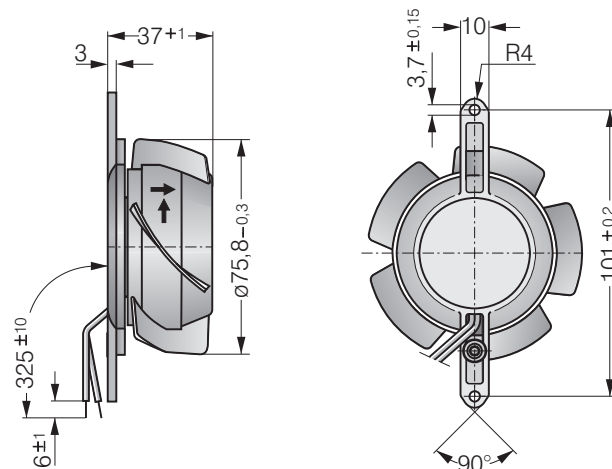

max. 47 m<sup>3</sup>/h

## AC axial fans

Series 8000 TV 76 Ø x 37 mm

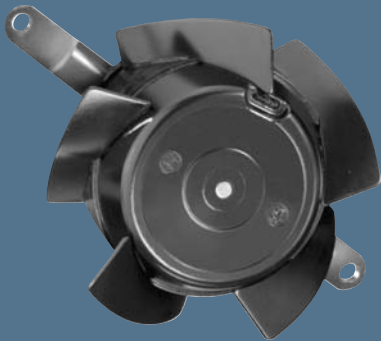

- AC fans with external rotor shaded-pole motor. Impedance protected against overloading.
- Impeller and mounting bracket of metal.
- Air exhaust over mounting bracket. Direction of rotation clockwise, seen on rotor.
- Electrical connection via 2 leads. Bared and tin-plated.
- Mass: 370 g.
- Please note our new ACmaxx series. With identical mounting dimensions and voltages, this series achieves higher energy efficiency.

Nominal data	Air flow		Nominal voltage	Frequency	Sound pressure level	Sinter sleeve bearings Ball bearings	Power input	Nominal speed	Temperature range	Service life L <sub>10</sub>		Curve
	m <sup>3</sup> /h	CFM								V	Hz	
8880 TV	24	14,1	230	50	15	□	9,0	1 650	-10...+80	60 000 / 25 000		-
8850 TV	31	18,2	230	50	20	□	12,0	2 100	-10...+70	52 500 / 25 000		-
8550 TV	40	23,5	230	50	27	□	12,0	2 650	-10...+70	52 500 / 25 000		-
8556 TV	40	23,5	230	50	28	■	12,0	2 750	-40...+90	52 500 / 15 000		-
8830 TV	27	15,9	115	60	18	□	8,0	1 850	-10...+80	62 500 / 25 000		-
8800 TV	36	21,2	115	60	24	□	11,0	2 450	-10...+70	55 000 / 27 500		-
8500 TV	47	27,7	115	60	32	□	11,0	3 150	-10...+75	55 000 / 25 000		-
8506 TV	47	27,7	115	60	33	■	11,0	3 250	-40...+95	55 000 / 15 000		-

The air flow and noise level of fans without external housing depends on the installation conditions. The stated air flow and noise has been measured with an orifice 76.5 mm Ø at a distance of approx. 17 mm from the mounting bracket. Under exceptionally favourable mounting conditions, the air flow of fan series 8000 N is achievable. The noise in the optimal operating range can only be measured for these fans in a specific application.

Fan type	Lead wires				
8880 TV	8850 TV	8830 TV	8800 TV	325 mm long	AWG 18, TR 64
8550 TV	8500 TV			325 mm long	AWG 18, TR 64
8556 TV	8506 TV			325 mm long	AWG 18

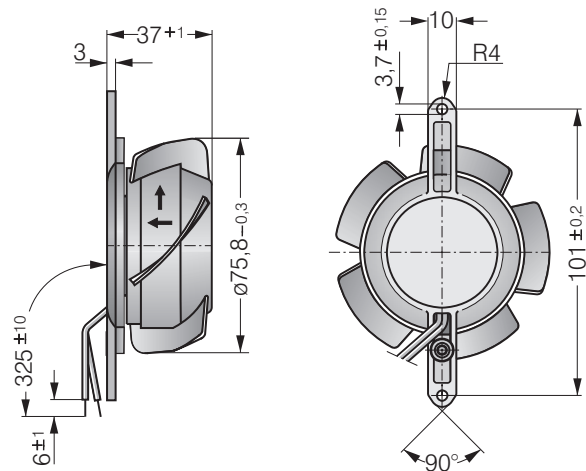

max. 70 m<sup>3</sup>/h

# AC axial fans

Series 3900 92 x 92 x 25 mm



- AC fans with internal rotor shaded-pole motor. Impedance protected against overloading.
- Metal fan housing, impeller of mineral-reinforced plastic PA.
- Air exhaust over struts. Direction of rotation counter-clockwise, seen on rotor.
- Electrical connection via 2 flat plugs 2.8 x 0.5 mm.
- Fan housing with grounding lug for screw M4.
- Mass: 280 g.
- Please note our new ACmaxx series. With identical mounting dimensions and voltages, this series achieves higher energy efficiency.

Nominal data	Air flow		Nominal voltage	Frequency	Sound pressure level	Sound power level	Sinter sleeve bearings Ball bearings	Power input	Nominal speed	Temperature range	Service life L <sub>10</sub>		Curve
	m <sup>3</sup> /h	CFM									at 40 °C	at T <sub>max</sub>	
Type	m <sup>3</sup> /h	CFM	V	Hz	dB(A)	Bel(A)	□/■	Watts	RPM	°C	Hours	Hours	
3950 L	31	18,2	230	50	24	3,8	□	6,0	1 550	-10...+80	70 000 / 27 500	1	1
3956 L	31	18,2	230	50	24	3,8	■	6,0	1 550	-40...+80	70 000 / 27 500	1	1
3950 M	45	26,5	230	50	29	4,2	□	6,0	2 150	-10...+80	70 000 / 27 500	2	2
3956 M	45	26,5	230	50	29	4,2	■	6,0	2 150	-40...+80	70 000 / 27 500	2	2
3950	59	34,7	230	50	35	4,7	□	11,0	2 650	-20...+80	55 000 / 20 000	3	3
3956	59	34,7	230	50	35	4,7	■	11,0	2 650	-40...+80	55 000 / 20 000	3	3
3900 L	39	23,0	115	60	27	4,0	□	5,0	1 850	-10...+80	70 000 / 27 500	4	4
3906 L	39	23,0	115	60	27	4,0	■	5,0	1 850	-40...+80	70 000 / 27 500	4	4
3900 M	53	31,2	115	60	34	4,6	□	5,0	2 600	-10...+80	70 000 / 27 500	5	5
3906 M	53	31,2	115	60	34	4,6	■	5,0	2 600	-40...+80	70 000 / 27 500	5	5
3900	70	41,2	115	60	40	5,1	□	9,0	3 150	-20...+80	60 000 / 22 500	6	6
3906	70	41,2	115	60	40	5,1	■	9,0	3 150	-40...+80	60 000 / 22 500	6	6

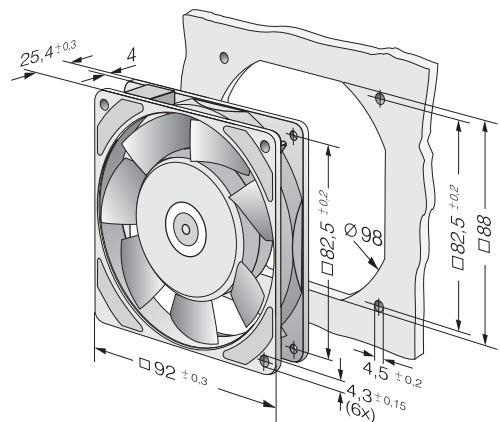
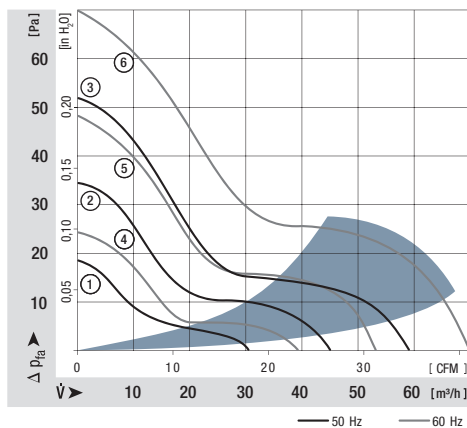



max. 89 m<sup>3</sup>/h

# AC axial fans

Series 3000 92 x 92 x 38 mm

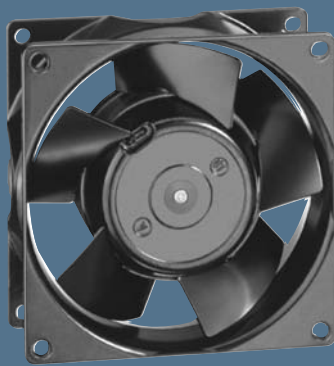

- AC fans with external rotor shaded-pole motor. Impedance protected against overloading.
- Metal fan housing and impeller.
- Air exhaust over struts. Rotational direction CW looking at rotor.
- Electrical connection via 2 leads. Bared and tin-plated.
- Fan housing with grounding lug and screw M4 x 8 (TORX).
- Mass: 420 g.
- Please note our new ACmaxx series. With identical mounting dimensions and voltages, this series achieves higher energy efficiency.

Nominal data		Air flow	Air flow	Nominal voltage	Frequency	Sound pressure level	Sound power level	Sinter sleeve bearings Ball bearings	Power input	Nominal speed	Temperature range	Service life L <sub>10</sub> at 40 °C	at T <sub>max</sub>	Curve
Type		m <sup>3</sup> /h	CFM	V	Hz	dB(A)	Bel(A)	□ / ■	Watts	RPM	°C	Hours	Hours	
3850		49	28,8	230	50	24	3,7	□	9,0	1 750	-10...+75	60 000 / 27 500		1
3856		54	31,8	230	50	26	3,9	■	9,0	1 950	-40...+90	60 000 / 20 000		2
3550		67	39,4	230	50	32	4,4	□	8,5	2 300	-10...+80	60 000 / 25 000		3
3556		67	39,4	230	50	33	4,5	■	8,5	2 400	-40...+90	60 000 / 20 000		3
3650		75	44,1	230	50	36	4,8	□	12,0	2 650	-10...+55	52 500 / 37 500		4
3656		75	44,1	230	50	37	4,9	■	12,0	2 700	-40...+75	52 500 / 22 500		4
3800		54	31,8	115	60	26	3,9	□	8,0	1 900	-10...+80	62 500 / 25 000		5
3806		60	35,3	115	60	29	4,2	■	8,0	2 150	-40...+95	62 500 / 17 500		6
3500		73	43,0	115	60	35	4,6	□	8,0	2 500	-10...+80	62 500 / 25 000		7
3506		73	43,0	115	60	36	4,7	■	8,0	2 600	-40...+95	62 500 / 17 500		7
3600		89	52,4	115	60	41	5,1	□	11,0	3 100	-10...+65	55 000 / 30 000		8
3606		89	52,4	115	60	42	5,2	■	11,0	3 200	-40...+75	55 000 / 25 000		8

Fan type	Lead wires	
With sleeve bearings	310 mm long	AWG 18, TR 64
With ball bearings	310 mm long	AWG 18

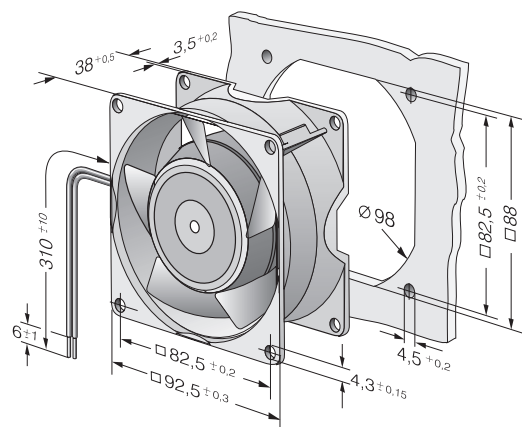
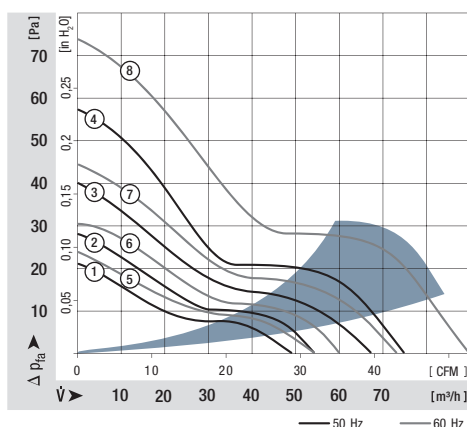

max. 135 m<sup>3</sup>/h

# AC axial fans

Series 9900 119 x 119 x 25 mm



- AC fans with external rotor shaded-pole motor.  
Protected against overloading by thermal cut-out.
- Metal fan housing and impeller.
- Air exhaust over struts. Direction of rotation counter-clockwise, seen on rotor.
- Electrical connection via 2 flat plugs 2.8 x 0.5 mm.
- Fan housing with grounding lug and screw M4 x 8 (TORX).
- Mass: 320 g.
- Please note our new ACmaxx series. With identical mounting dimensions and voltages, this series achieves higher energy efficiency.

Nominal data		Air flow	Air flow	Nominal voltage	Frequency	Sound pressure level	Sound power level	Sinter sleeve bearings Ball bearings	Power input	Nominal speed	Temperature range	Service life L <sub>10</sub> at 40 °C	at T <sub>max</sub>	Curve
Type		m <sup>3</sup> /h	CFM	V	Hz	dB(A)	Bel(A)	■ / □	Watts	RPM	°C	Hours	Hours	
9956 L		84	49,4	230	50	29	4,4	■	9,5	1850	-40...+80	57 500 / 22 500		1
9956 M		104	61,2	230	50	35	4,7	■	10,0	2250	-40...+80	57 500 / 22 500		2
9950		117	68,9	230	50	37	5,0	□	14,0	2450	-20...+70	47 500 / 22 500		3
9956		117	68,9	230	50	37	5,0	■	14,0	2450	-40...+70	47 500 / 22 500		3
9906 L		100	58,9	115	60	34	4,6	■	8,0	2100	-40...+80	62 500 / 25 000		4
9906 M		111	65,3	115	60	37	5,0	■	8,0	2450	-40...+80	62 500 / 25 000		5
9900		135	79,5	115	60	42	5,4	□	12,0	2850	-20...+70	52 500 / 25 000		6
9906		135	79,5	115	60	42	5,4	■	12,0	2850	-40...+70	52 500 / 25 000		6

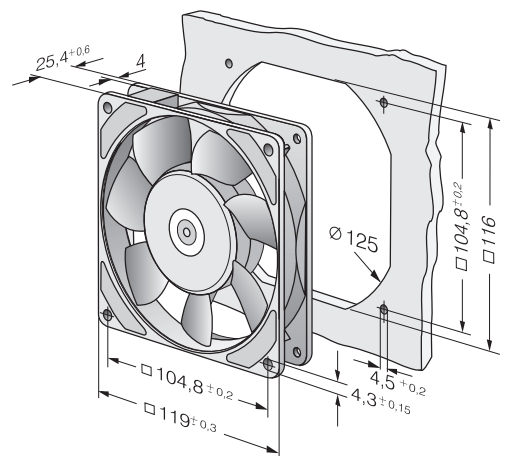
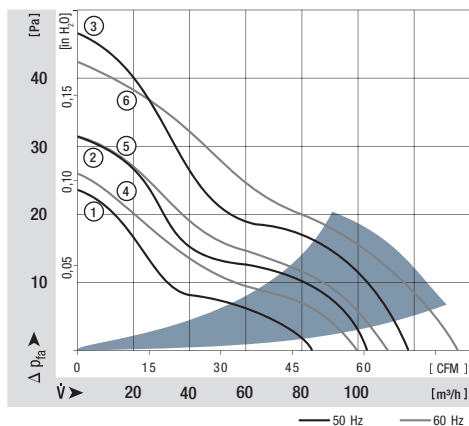

max. 180 m<sup>3</sup>/h

# AC axial fans

Series 4000 N 119 x 119 x 38 mm

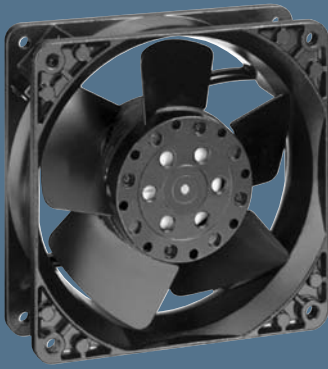

- AC fans with external rotor shaded-pole motor. Impedance protected against overloading.
- Metal fan housing and impeller
- Air intake over struts. Direction of rotation clockwise, seen on rotor.
- Types 4890 N and 4840 N air exhaust over struts.
- Electrical connection via 2 flat plugs 3.0 x 0.5 mm.
- Impeller with 3 or 5 blades, see note for fan type.
- Optionally available: Models with reinforced flanges and single leads.
- Fan housing with grounding lug for screw M 4 and UNC.
- Mass: 550 g.
- Please note our new ACmaxx series. With identical mounting dimensions and voltages, this series achieves higher energy efficiency.

Nominal data	Air flow		Nominal voltage	Frequency	Sound pressure level	Sound power level	Sinter sleeve bearings Ball bearings	Power input	Nominal speed	Temperature range	Service life L <sub>10</sub>		Curve
	m <sup>3</sup> /h	CFM									Hours	Hours	
4890 N	80	47,1	230	50	25	4,0	□	11,0	1 550	-10...+70	55 000 / 27 500	1	
4850 N*	100	58,9	230	50	32	4,4	□	10,0	1 800	-10...+70	57 500 / 27 500	2	
4580 N*	123	72,4	230	50	41	5,2	□	18,0	2 350	-10...+55	40 000 / 27 500	3	
4550 N*	145	85,3	230	50	44	5,4	□	16,5	2 550	-10...+55	42 500 / 30 000	4	
4650 N	160	94,2	230	50	46	5,4	□	19,0	2 650	-10...+55	37 500 / 27 500	5	
4656 N	160	94,2	230	50	47	5,5	■	19,0	2 650	-40...+85	37 500 / 15 000	5	
4840 N	85	50,0	115	60	26	4,1	□	10,0	1 650	-10...+75	57 500 / 25 000	6	
4800 N*	97	57,1	115	60	32	4,3	□	9,0	1 750	-10...+75	60 000 / 27 500	7	
4530 N*	151	88,9	115	60	45	5,4	□	16,0	2 700	-10...+65	42 500 / 25 000	8	
4500 N*	169	99,5	115	60	48	5,7	□	15,0	3 000	-10...+65	47 500 / 25 000	9	
4600 N	180	105,9	115	60	50	5,7	□	18,0	3 100	-10...+60	40 000 / 25 000	10	
4606 N	180	105,9	115	60	51	5,8	■	18,0	3 100	-40...+90	40 000 / 15 000	10	

230 V and 115 V versions are rated for both 50 Hz and 60 Hz operation.  
For 60 Hz data, please refer to the corresponding 115 V 60 Hz model,  
for 50 Hz data please refer to the corresponding 230 V 50 Hz model.

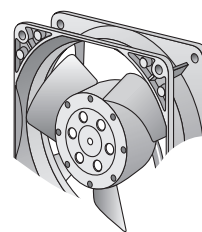
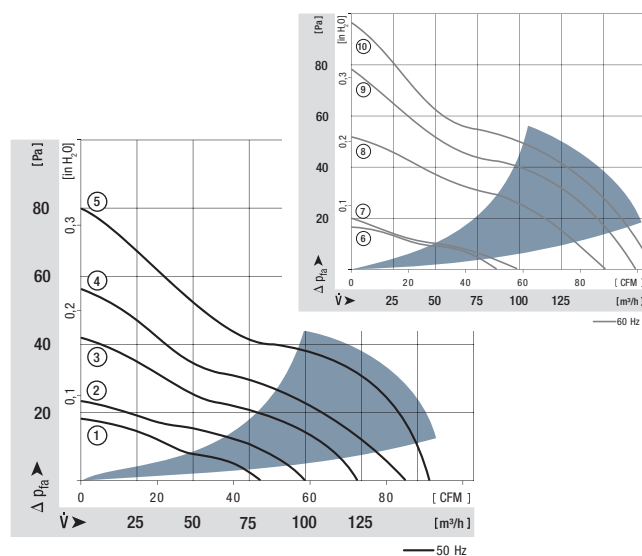

\* Fan with 3 blades.

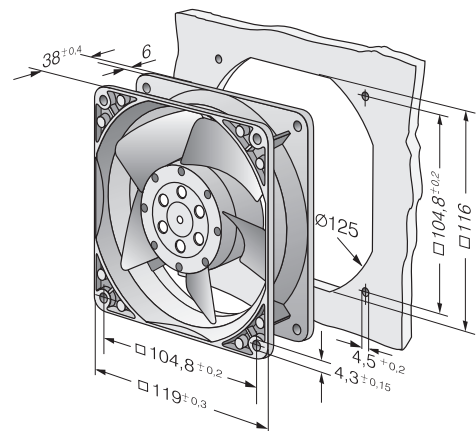

max. 180 m<sup>3</sup>/h

# AC axial fans

Series 4000 Z 119 x 119 x 38 mm



- AC fans with external rotor shaded-pole motor. Impedance protected against overloading.
- Metal fan housing and impeller.
- Air exhaust over struts. Direction of rotation clockwise, seen on rotor.
- Electrical connection via 2 flat plugs 2.8 x 0.5 mm.
- Optionally available: Models with reinforced flanges and single leads.
- Fan housing with grounding lug and screw M4 x 8 (TORX).
- Mass: 540 g.
- Please note our new ACmaxx series. With identical mounting dimensions and voltages, this series achieves higher energy efficiency.

Nominal data	Air flow		Nominal voltage	Frequency	Sound pressure level	Sound power level	Sinter sleeve bearings Ball bearings	Power input	Nominal speed	Temperature range	Service life L <sub>10</sub>		Curve
	m <sup>3</sup> /h	CFM									at 40 °C	at T <sub>max</sub>	
Type	m <sup>3</sup> /h	CFM	V	Hz	dB(A)	Bel(A)	□ / ■	Watts	RPM	°C	Hours	Hours	
4850 Z	100	58,9	230	50	26	4,0	□	13,0	1 700	-10...+65	50 000 / 27 500	1	1
4856 Z	100	58,9	230	50	26	4,0	■	13,0	1 700	-40...+75	50 000 / 20 000	1	1
4580 Z	115	67,7	230	50	30	4,3	□	13,0	1 900	-10...+65	50 000 / 27 500	2	2
4586 Z	115	67,7	230	50	30	4,3	■	13,0	1 900	-40...+75	50 000 / 20 000	2	2
4650 Z	160	94,2	230	50	40	5,3	□	19,0	2 650	-10...+50	37 500 / 30 000	3	3
4656 Z	160	94,2	230	50	40	5,3	■	19,0	2 650	-40...+75	37 500 / 17 500	3	3
4800 Z	105	61,6	115	60	28	4,1	□	12,0	1 800	-10...+70	52 500 / 25 000	4	4
4806 Z	105	61,6	115	60	28	4,1	■	12,0	1 800	-40...+75	52 500 / 17 500	4	4
4530 Z	120	70,6	115	60	32	4,4	□	12,0	2 000	-10...+70	52 500 / 25 000	5	5
4536 Z	120	70,6	115	60	32	4,4	■	12,0	2 000	-40...+75	52 500 / 17 500	5	5
4600 Z	180	105,9	115	60	45	5,6	□	18,0	3 100	-10...+60	40 000 / 25 000	6	6
4606 Z	180	105,9	115	60	45	5,6	■	18,0	3 100	-40...+85	40 000 / 15 000	6	6

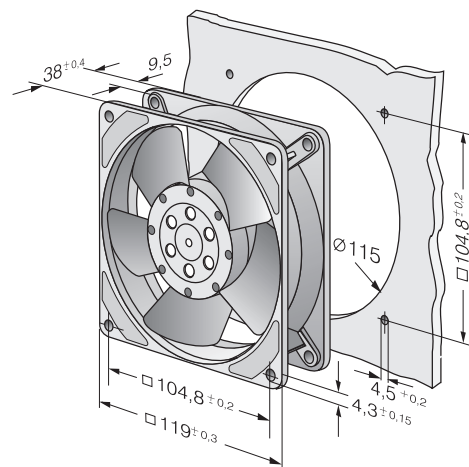
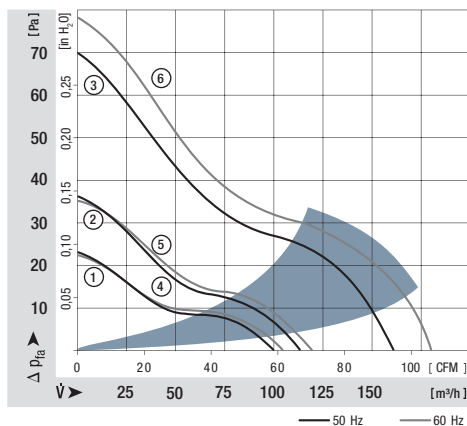

max. 147 m<sup>3</sup>/h

# AC axial fans

Series 4600 TA 113 Ø x 37 mm

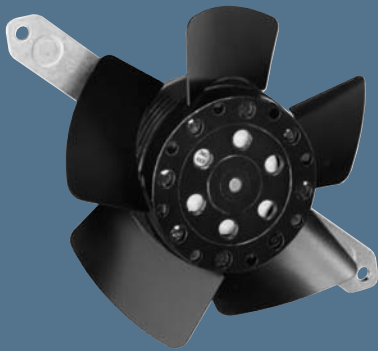

- AC fans with external rotor shaded-pole motor. Impedance protected against overloading.
- Impeller and mounting bracket of metal.
- Air intake over mounting bracket. Direction of rotation clockwise, seen on rotor.
- Electrical connection via 2 leads. Bared and tin-plated.
- Mass: 430 g.
- Please note our new ACmaxx series. With identical mounting dimensions and voltages, this series achieves higher energy efficiency.

Nominal data		Air flow	Air flow	Nominal voltage	Frequency	Sound pressure level	Sinter sleeve bearings Ball bearings	Power input	Nominal speed	Temperature range	Service life L <sub>10</sub> at 40 °C	at T <sub>max</sub>	Curve
Type		m <sup>3</sup> /h	CFM	V	Hz	dB(A)	□ / ■	Watts	RPM	°C	Hours	Hours	
4650 TA		138	81,2	230	50	41	□	19,0	2 550	-10...+45	37 500 / 32 500	-	-
4656 TA		138	81,2	230	50	42	■	19,0	2 550	-40...+75	37 500 / 17 500	-	-
4600 TA		147	86,5	115	60	43	□	18,0	2 900	-10...+50	40 000 / 32 500	-	-
4606 TA		147	86,5	115	60	44	■	18,0	2 900	-40...+80	40 000 / 17 500	-	-

The air flow and noise level of fans without external housing depends on the installation conditions. The stated air flow and noise has been measured with an orifice 109 mm Ø at a distance of approx. 17 mm from the mounting bracket. Under exceptionally favourable mounting conditions, the air flow of fan series 4600 N is achievable. The noise in the optimal operating range can only be measured for these fans in a specific application.

Fan type	Lead wires
4650 TA	4600 TA
4656 TA	4606 TA

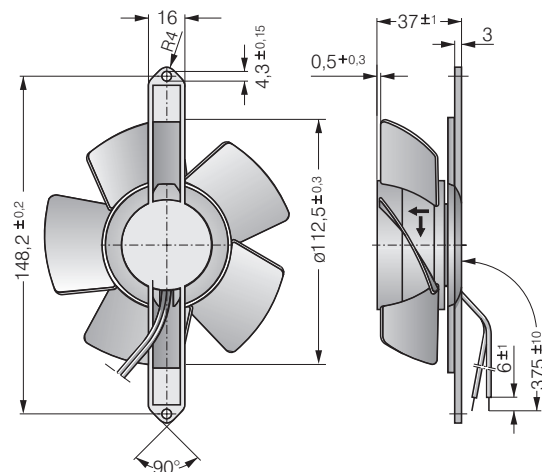

max. 140 m<sup>3</sup>/h

## AC axial fans

Series 4600 TZ 108 Ø x 37 mm

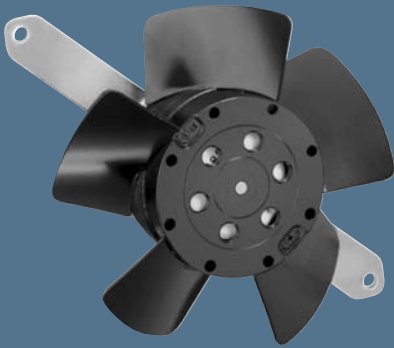

- AC fans with external rotor shaded-pole motor. Impedance protected against overloading.
- Impeller and mounting bracket of metal.
- Air exhaust over mounting bracket. Direction of rotation clockwise, seen on rotor.
- Electrical connection via 2 leads. Bared and tin-plated.
- Mass: 430 g.
- Please note our new ACmaxx series. With identical mounting dimensions and voltages, this series achieves higher energy efficiency.

Nominal data		Air flow	Air flow	Nominal voltage	Frequency	Sound pressure level	Sinter sleeve bearings Ball bearings	Power input	Nominal speed	Temperature range	Service life L <sub>10</sub> at 40 °C	at T <sub>max</sub>	Curve
Type		m <sup>3</sup> /h	CFM	V	Hz	dB(A)	□ / ■	Watts	RPM	°C	Hours	Hours	
4650 TZ		125	73,6	230	50	42	□	19,0	2 600	-10...+50	37 500 / 37 500		-
4656 TZ		125	73,6	230	50	42	■	19,0	2 600	-40...+65	37 500 / 20 000		-
4600 TZ		140	82,4	115	60	45	□	18,0	2 950	-10...+50	40 000 / 32 500		-
4606 TZ		140	82,4	115	60	45	■	18,0	2 950	-40...+75	40 000 / 17 500		-

The air flow and noise level of fans without external housing depends on the installation conditions. The stated air flow and noise has been measured with an orifice 109 mm Ø at a distance of approx. 17 mm from the mounting bracket. Under exceptionally favourable mounting conditions, the air flow of fan series 4000 Z is achievable. The noise in the optimal operating range can only be measured for these fans in a specific application.

Fan type		Lead wires
4650 TZ	4600 TZ	AWG 22, TR 32
4656 TZ	4606 TZ	AWG 18

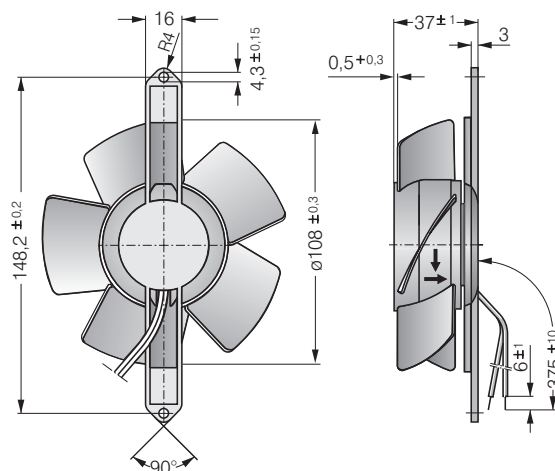

max. 206 m<sup>3</sup>/h

# AC axial fans

Series 5900 127 x 127 x 38 mm



- AC fans with internal rotor shaded-pole motor. Impedance protected against overloading.
- Metal fan housing and impeller of fibreglass-reinforced plastic PA.
- Air exhaust over struts. Direction of rotation counter-clockwise, seen on rotor.
- Electrical connection via 2 flat plugs 2.8 x 0.8 mm.
- Fan housing with grounding lug and screw M4 x 6.
- Mass: 570 g.
- Please note our new ACmaxx series. With identical mounting dimensions and voltages, this series achieves higher energy efficiency.

Nominal data		Air flow	Air flow	Nominal voltage	Frequency	Sound pressure level	Sound power level	Sinter sleeve bearings Ball bearings	Power input	Nominal speed	Temperature range	Service life L <sub>10</sub> at 40 °C	at T <sub>max</sub>	Curve
Type		m <sup>3</sup> /h	CFM	V	Hz	dB(A)	Bel(A)	■ / □	Watts	RPM	°C	Hours	Hours	
5988		150	88,3	230	50	37	4,9	■	13,0	2 250	-30...+55	35 000 / 20 000		1
5950		180	105,9	230	50	43	5,4	□	18,0	2 700	-20...+50	40 000 / 32 500		3
5958		180	105,9	230	50	44	5,5	■	18,0	2 750	-30...+60	40 000 / 25 000		3
5938		162	95,3	115	60	40	4,9	■	12,0	2 500	-30...+55	35 000 / 20 000		2
5900		206	121,2	115	60	46	5,7	□	17,0	3 050	-20...+55	42 500 / 30 000		4
5908		206	121,2	115	60	47	5,8	■	17,0	3 100	-30...+75	42 500 / 20 000		4

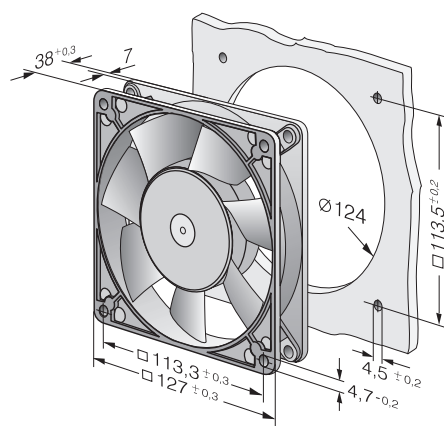
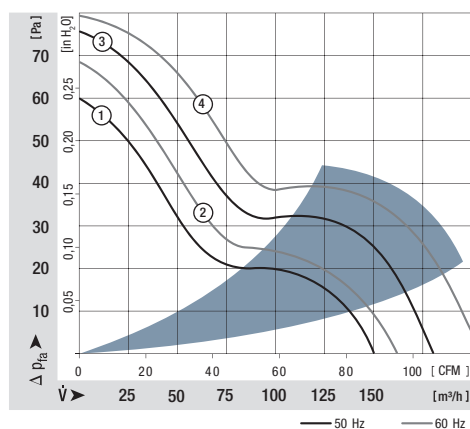

max. 270 m<sup>3</sup>/h

# AC axial fans

Series 5600 135 x 135 x 38 mm

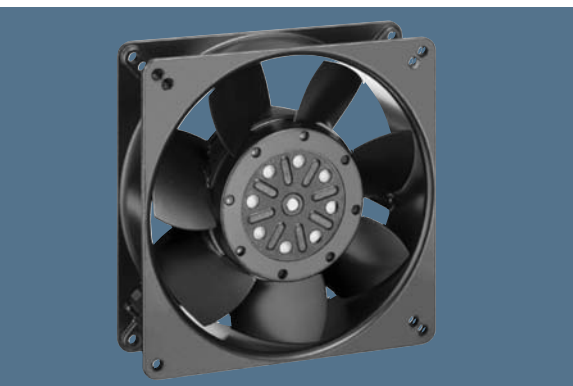

- AC fans with external rotor shaded-pole motor. Protected against overloading by thermal cut-out.
- Metal fan housing and impeller.
- Air exhaust over struts. Direction of rotation counter-clockwise, seen on rotor.
- Electrical connection via 2 flat plugs 2.8 x 0.5 mm.
- Fan housing with grounding lug and screw M4 x 8 (TORX).
- Mass: 800 g.
- Please note our new ACmaxx series. With identical mounting dimensions and voltages, this series achieves higher energy efficiency.

Nominal data		Air flow	Air flow	Nominal voltage	Frequency	Sound pressure level	Sound power level	Sinter sleeve bearings Ball bearings	Power input	Nominal speed	Temperature range	Service life L <sub>10</sub> at 40 °C	at T <sub>max</sub>	Curve
Type		m <sup>3</sup> /h	CFM	V	Hz	dB(A)	Bel(A)	■ / ■	Watts	RPM	°C	Hours	Hours	
5656 S		235	138,3	<b>230</b>	<b>50</b>	46	5,9	■	30,0	2 700	-35...+70	45 000 / 20 000		1
5606 S		270	158,9	<b>115</b>	<b>60</b>	50	6,2	■	26,0	3 100	-35...+80	47 500 / 20 000		2

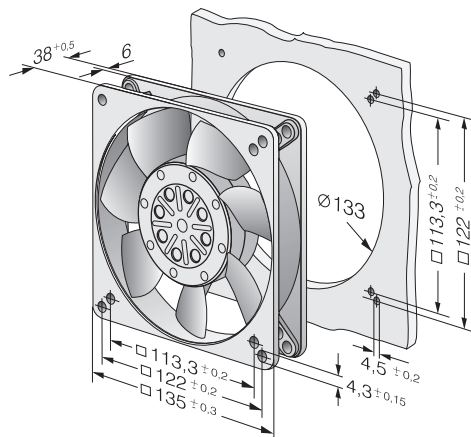
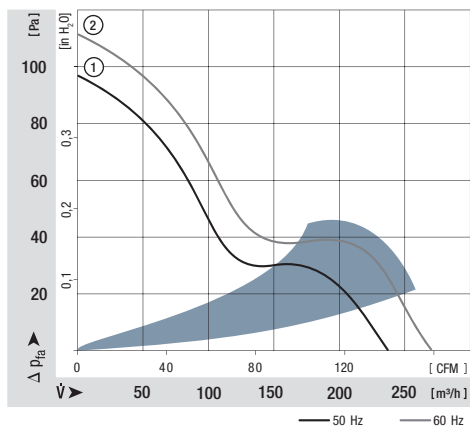



max. 380 m<sup>3</sup>/h

## AC axial fans

Series 7000 150 x 172 x 38 mm

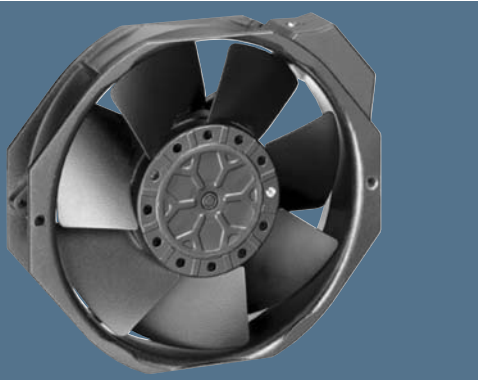

- AC fans with external rotor capacitor motor. Protected against overloading by integrated thermal cut-out.
- Metal fan housing and impeller.
- Air exhaust over struts. Direction of rotation counter-clockwise, seen on rotor.
- Electrical connection via 2 flat plugs 2.8 x 0.5 mm.
- Fan housing with grounding lug and screw M4 x 6.
- Mass: 900 g.
- Please note our new ACmaxx series. With identical mounting dimensions and voltages, this series achieves higher energy efficiency.

Nominal data		Air flow	Air flow	Nominal voltage	Frequency	Sound pressure level	Sound power level	Sinter sleeve bearings Ball bearings	Power input	Nominal speed	Temperature range	Service life L <sub>10</sub> at 40 °C	at T <sub>max</sub>	Curve
Type		m <sup>3</sup> /h	CFM	V	Hz	dB(A)	Bel(A)	■ / ■	Watts	RPM	°C	Hours	Hours	
7056 ES		320	188,3	230	50	51	6,4	■	27,0	2 800	-25...+55	60 000 / 32 000		1
7006 ES		380	223,6	115	60	56	6,8	■	28,0	3 350	-25...+65	55 000 / 18 000		2

Minimum ambient temperature -15 °C.

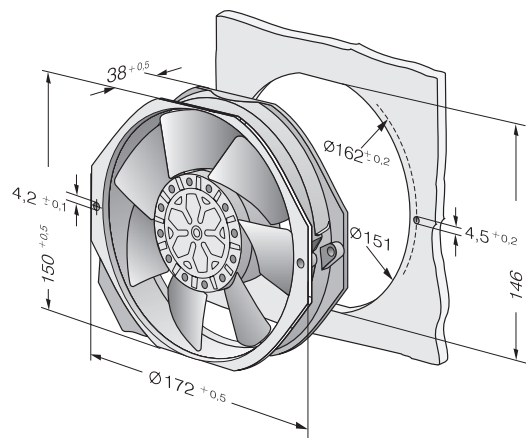
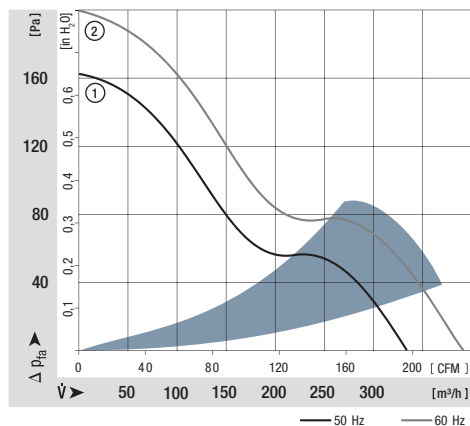

max. 380 m<sup>3</sup>/h

# AC axial fans

Series 7800 150 Ø x 55 mm



- AC fans with external rotor shaded-pole motor. Protected against overloading by integrated thermal cut-out.
- Metal fan housing and impeller.
- Air exhaust over struts. Direction of rotation counter-clockwise, seen on rotor.
- Electrical connection via 2 leads. Bared and tin-plated.
- Fan housing with grounding lug and screw M4 x 6.
- Mass: 1.1 kg.
- Please note our new ACmaxx series. With identical mounting dimensions and voltages, this series achieves higher energy efficiency.

Nominal data	Air flow		Nominal voltage	Frequency	Sound pressure level	Sound power level	Sinter sleeve bearings Ball bearings	Power input	Nominal speed	Temperature range	Service life L <sub>10</sub>		Curve
	m <sup>3</sup> /h	CFM									at 40 °C	at T <sub>max</sub>	
Type	m <sup>3</sup> /h	CFM	V	Hz	dB(A)	Bel(A)	■ / ■	Watts	RPM	°C	Hours	Hours	
7855 ES	325	191,3	230	50	49	6,0	■	45,0	2 800	-25...+50	60 000 / 47 000		1
7856 ES	325	191,3	230	50	49	6,0	■	45,0	2 800	-25...+70	60 000 / 23 000		1
7805 ES	380	223,7	115	60	53	6,4	■	38,0	3 250	-25...+70	60 000 / 47 000		2
7806 ES	380	223,7	115	60	53	6,4	■	38,0	3 250	-25...+90	60 000 / 18 000		2

Minimum ambient temperature -15 °C, admissible for a short time at -30 °C; without condensation.

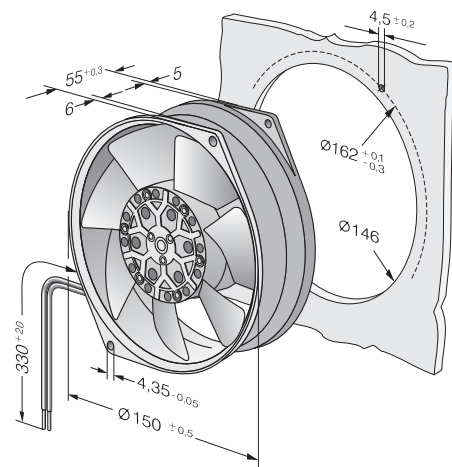
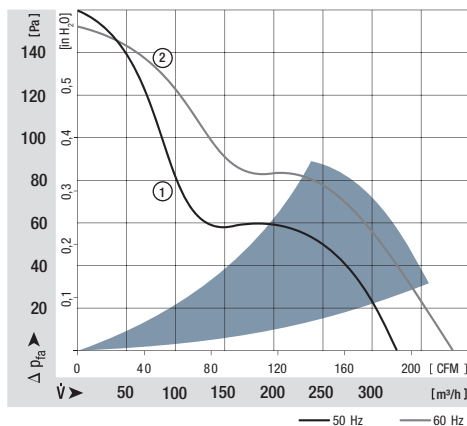

max. 425 m<sup>3</sup>/h

# AC axial fans

Series 7400 150 Ø x 55 mm

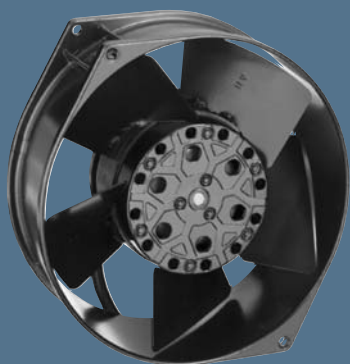

- AC fans with external rotor shaded-pole motor. Protected against overloading by integrated thermal cut-out.
- Metal fan housing and impeller.
- Air exhaust over struts. Direction of rotation counter-clockwise, seen on rotor.
- Electrical connection via 2 leads. Strand ends with brass lead tips.
- Fan housing with grounding lug and screw M4 x 6.
- Mass: 1.1 kg.
- Please note our new ACmaxx series. With identical mounting dimensions and voltages, this series achieves higher energy efficiency.

Nominal data		Air flow	Air flow	Nominal voltage	Frequency	Sound pressure level	Sound power level	Sinter sleeve bearings Ball bearings	Power input	Nominal speed	Temperature range	Service life L <sub>10</sub> at 40 °C	at T <sub>max</sub>	Curve
Type		m <sup>3</sup> /h	CFM	V	Hz	dB(A)	Bel(A)	■ / ■	Watts	RPM	°C	Hours	Hours	
7450 ES		380	223,6	230	50	60	6,8	■	47,0	2 700	-25...+50	63 000 / 50 000		1
7400 ES		425	250,1	115	60	62	6,9	■	46,0	3 050	-25...+70	50 000 / 24 000		2

Minimum ambient temperature -15 °C, admissible for a short time at -30 °C; without condensation.

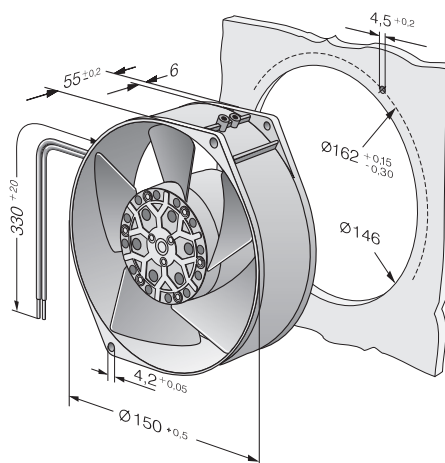
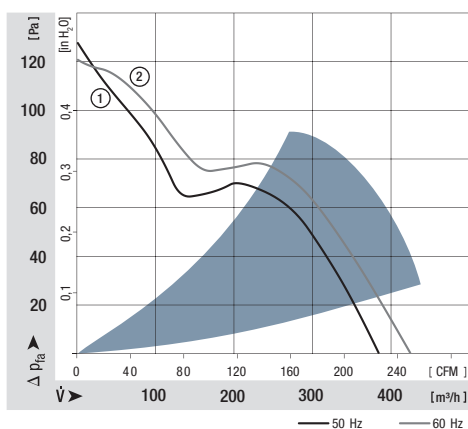

max. 500 m<sup>3</sup>/h

# AC axial fans

Series 6000 172 Ø x 51 mm



- AC fans with external rotor capacitor motor. Protected against overloading by integrated thermal cut-out.
- Metal fan housing and impeller.
- Air exhaust over struts. Direction of rotation counter-clockwise, seen on rotor.
- Electrical connection via 2 flat plugs 2.8 x 0.5 mm.
- Fan housing with grounding lug and screw M4 x 6.
- Mass: 1.0 kg.
- Please note our new ACmaxx series. With identical mounting dimensions and voltages, this series achieves higher energy efficiency.

Nominal data	Air flow		Nominal voltage	Frequency	Sound pressure level	Sound power level	Sinter sleeve bearings Ball bearings	Power input	Nominal speed	Temperature range	Service life L <sub>10</sub>		Curve
	m <sup>3</sup> /h	CFM									V	Hz	
6058 ES	375	220,7	230	50	55	5,9	■	24,0	2 800	-25...+70	62 000 / 31 000		1
6078 ES	420	247,2	230	50	54	6,3	■	26,0	2 800	-25...+60	62 000 / 39 000		2
6008 ES	440	259,0	115	60	60	6,4	■	26,0	3 300	-25...+70	57 000 / 28 000		3
6028 ES	500	284,3	115	60	58	6,7	■	29,0	3 300	-25...+75	57 000 / 22 000		4

Minimum ambient temperature -15 °C, admissible for a short time at -30 °C; without condensation.

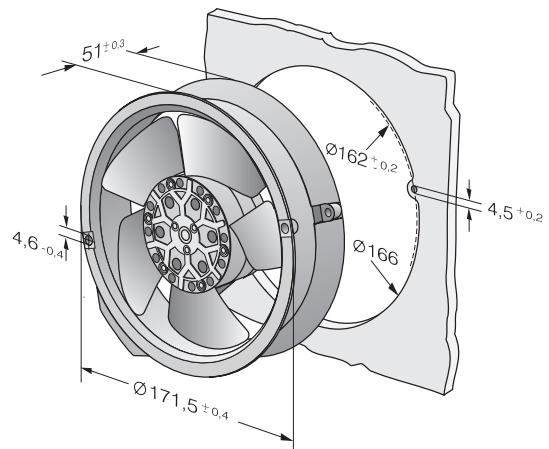
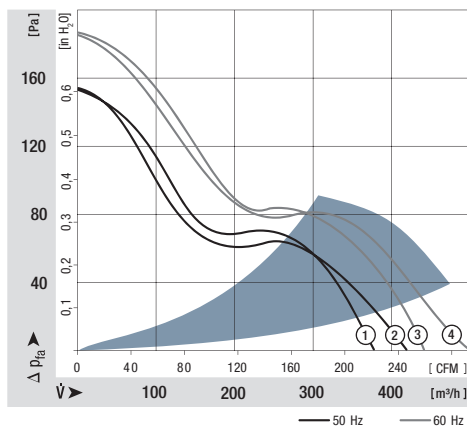

max. 1030 m<sup>3</sup>/h

# AC axial fans

W\*\* 200 225 x 225 x 80 mm



- External-rotor single-phase motor.\* / External rotor shaded-pole motor.\*\*
- Motor protection: TOP wired internally.
- Material: Wall ring die-cast aluminium, seven blades of sheet steel. Blades and rotor coated in black.
- Direction of air flow "V", air exhaust over struts. Direction of rotation: counter-clockwise, seen on rotor.
- Electrical connection: Terminal strip (operating capacitor connected).
- Continuous operation (S1).
- Insulation class: "F"
- Mass: 2 kg.
- Please note our new ACmaxx series. With identical mounting dimensions and voltages, this series achieves higher energy efficiency.

Nominal data		Air flow	Air flow	Nominal voltage	Frequency	Sound pressure level	Sound power level	Sleeve bearings Ball bearings	Power input	Nominal speed	Temperature range	Service life L <sub>10</sub> at 40 °C	at T <sub>max</sub>	Curve
Type		m <sup>3</sup> /h	CFM	V	Hz	dB(A)	Bel(A)	□ / ■	Watts	RPM	°C	Hours	Hours	
W2E200-HK86-01*		1030	606,2	115	60	61	6,7	■	80,0	2800	-25...+65	60 000 / 58 000		2
W2E200-HK38-01*		880	517,9	230	50	58	6,6	■	64,0	2550	-25...+60	63 000 / 60 000		2
W4S200-HK04-01**		450	264,9	230	50	40	4,7	■	30,0	1370	-25...+70	85 000 / 80 000		1

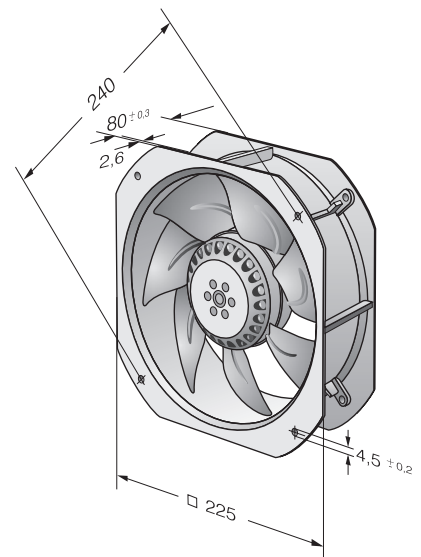
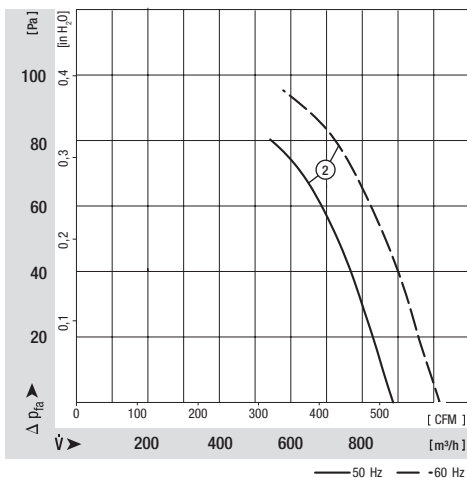
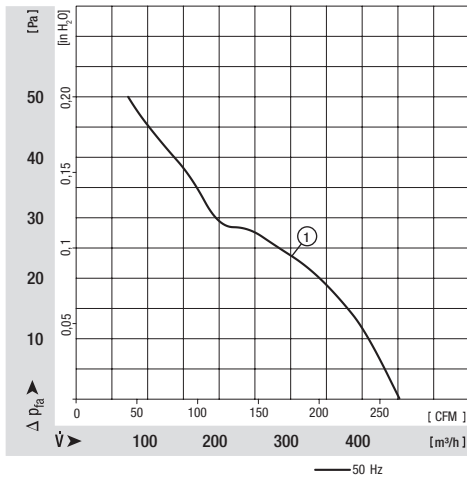

max. 1865 m<sup>3</sup>/h

# AC axial fans

W2E 250 280 x 280 x 80 mm



- External-rotor single-phase motor.
- Motor protection: TOP wired internally.
- Material: Wall ring die-cast aluminium, seven blades of sheet steel. Blades and rotor coated in black.
- Direction of air flow "V", air exhaust over struts. Direction of rotation: counter-clockwise, seen on rotor.
- Electrical connection: Terminal strips (operating capacitor connected).
- Continuous operation (S1).
- Insulation class: "F"
- Mass: 2 kg.
- Please note our new ACmaxx series. With identical mounting dimensions and voltages, this series achieves higher energy efficiency.

Nominal data		Air flow	Air flow	Nominal voltage	Frequency	Sound pressure level	Sound power level	Sleeve bearings Ball bearings	Power input	Nominal speed	Temperature range	Service life L <sub>10</sub> at 40 °C	at T <sub>max</sub>	Curve
Type	m <sup>3</sup> /h	CFM	V	Hz	dB(A)	Bel(A)	□ / ■	Watts	RPM	°C	Hours	Hours		
W2E 250-HL06-01	1865	1077,1	230	50	66	7,2	■	127,0	2 550	-25...+60	63 000 / 70 000		3	

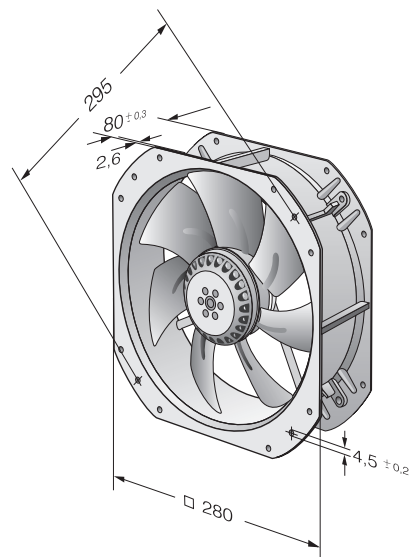
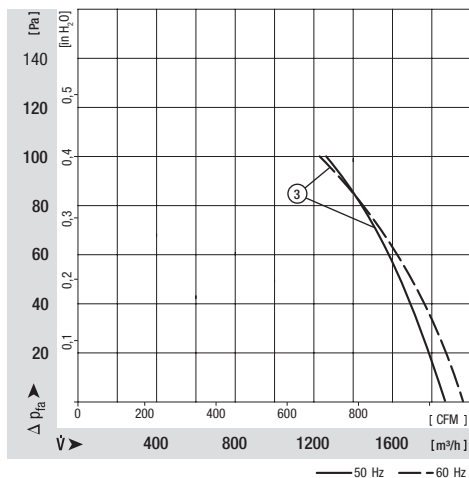

# AC centrifugal fans

AC centrifugal fan overview	165
AC centrifugal fans	166



## Technical information

### Product line

The renowned ebm-papst AC fans are used when DC voltage is not available. The AC range of fans is based on experience gained from decades of development activity, millions of units in series production and competence in innovation of a world-wide technological leader.

A wide range of fans for AC operation is presented in this catalogue. In addition to complete device fans, you will also find fans without external housing, providing a particularly economical advantage when the air duct can be integrated in the respective device.

### Variety of sizes

AC fans are available in a variety of sizes with either air exhaust or air intake over struts. Silent running models with sleeve bearings or for extreme ambient conditions; fans with ball bearings are available with plug connection or external leads.

### Shaded-pole or capacitor motors

Fan drives by shaded-pole or capacitor motors, most of which incorporate the world-famous ebm-papst external rotor principle: The fan blades are directly attached to the external rotor of the external rotor motor, thus combining both high performance and profitability.

### Flat built AC fans

ebm-papst also has particularly flat built AC fans with internal rotor motor. Their advantage: quick start to full speed. A plastic impeller and the both smaller and lighter internal rotor motor lead to a lower moment of inertia.

### Bearings

AC fans with sleeve bearings are powered by Class E insulated motors. Fans with ball bearings are equipped with Class B, E or F insulated motors.

### Protection class

All ebm-papst fans conform to the requirements of IP 20. Fans conforming to IP 54 and special types of protection class are also available.

### AC voltage

The line of AC fans for Euro voltage according to IEC 60038 (230 V + 6 %, -10 %) is basically also available for 115 V.

### Frequencies

AC fans can be operated at frequencies of 50 Hz or 60 Hz. However, their technical data then change accordingly.

### Capacitor

Fans driven by capacitor external motors provide particularly high operating efficiency. Generally, the required operating capacitor is already integrated in the fan housing.

### Overloading

Almost all AC fans are protected against overloading (e.g. due to locked rotor) the drive motors are either impedance protected (marked "Impedance protected", and/or "Z.P.") or are equipped with a thermal switch (marked "Thermally protected" or "Th.P."). The model designation of these fans ends with "S".



# Centrifugal fans for AC operation

## Overview of air performance

Dimension	Series	Air flow	Page
mm		m <sup>3</sup> /h	
□ 121 x 37	RL 90	40...42	166
□ 135 x 38	RG 90	47...54	167
□ 180 x 40	RG 125	86...94	168
□ 220 x 56	RG 160	202...223	169
∅ 138 x 40	RER 125	104...115	170
∅ 176 x 54	RER 160	234...274	171

## Overview of technically feasible designs

Centrifugal fans		Dimension	VDE, UL, CSA	Sleeve bearings/ ball bearings	Speed sensor	Humidity protection IP >= IP54	Salt spray fog protection	Page
Series	mm							
RL 90	121 x 121 x 37	yes	□ / ■	-	• • •	•	•	166
RG 90	135 x 135 x 38	yes	□ / ■	-	• • •	•	•	167
RG 125	180 x 180 x 40	yes	■	-	• • •	•	•	168
RG 160	220 x 220 x 56	yes	■	-	• • •	•	•	169
RER 125	138 ∅ x 40	yes	■	-	• • •	•	•	170
RER 160	176 ∅ x 54	yes	■	-	• • •	•	•	171

• available    - not yet available    □ Sleeve bearings    ■ Ball bearings

## Information on pictograms

On the pages of the catalogue and on the following overview pages, the pictograms illustrated below provide information about technically possible special versions in the fan line presented.

Please note that these special versions are not possible for all voltages and speeds, and not in all combinations.

The special versions are designed for specific customers and projects and are not usually available off the shelf.



### Speed signal

The fan uses a separate wire to output information about its speed, and thus about the speed of the rotor. For technical details, please refer to page 110.



### Protection against moisture

Protection for the fan's electronics against moisture and condensation. For technical details, please refer to page 123.



### IP 54

Protection of motor and PCB board against splashed water and humidity. For technical details, please refer to page 123.



### Protection against salt spray fog

Protection of fan against the damaging effects of salt spray fog. For technical details, please refer to page 123.

max. 42 m<sup>3</sup>/h

# AC centrifugal fans

Series RL 90 121 x 121 x 37 mm



- AC centrifugal fan with external rotor shaded-pole motor. Impedance protected against overloading.
- Spiral housing and impeller of fibreglass-reinforced plastic. Housing base of galvanised steel plate. Housing base with flat plug 6.3 x 0.8 mm for protective earth.
- Direction of air flow radial, through housing port. Direction of rotation clockwise, seen on rotor.
- Electrical connection via 2 leads. Bared and tin-plated.
- Mass: 680 g.

Nominal data	Air flow		Nominal voltage	Frequency	Sound power level	Sinter sleeve bearings Ball bearings	Power input	Nominal speed	Temperature range	Service life L <sub>10</sub>		Curve
	m <sup>3</sup> /h	CFM								V	Hz	
RL 90-18/50	40	23,5	230	50	5,6	□	20,0	2 450	-10...+50	37 500 / 30 000		1
RL 90-18/56	40	23,5	230	50	5,6	■	20,0	2 450	-30...+70	37 500 / 20 000		1
RL 90-18/00	42	24,7	115	60	6,0	□	19,5	2 550	-10...+60	37 500 / 25 000		2
RL 90-18/06	42	24,7	115	60	6,0	■	19,5	2 550	-30...+85	37 500 / 15 000		2

Fan type		Lead wires
RL 90-18/50	RL 90-18/00	AWG 18, TR 32
RL 90-18/56	RL 90-18/06	AWG 22

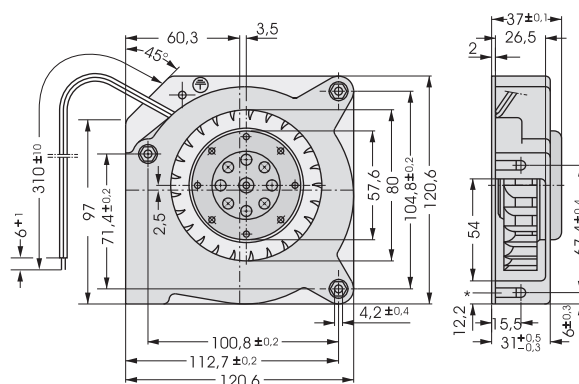
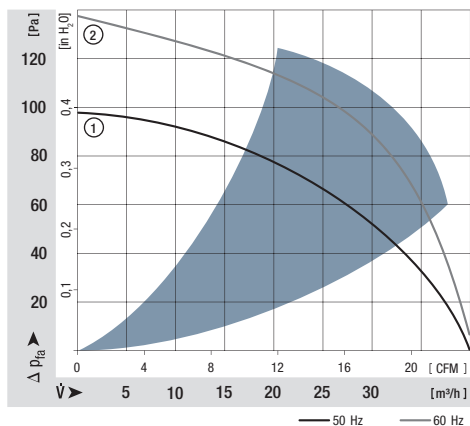

\*Speed nut M4 or 8-32UNC, Screw-in depth max.12,5 min 9,0

max. 54 m<sup>3</sup>/h

# AC centrifugal fans

Series RG 90 135 x 135 x 38 mm

- AC centrifugal fan with external rotor shaded-pole motor. Impedance protected against overloading.
- Spiral housing and impeller of fibreglass-reinforced plastic. Housing base of galvanised steel plate.
- Direction of air flow radial, through housing port. Direction of rotation clockwise, seen on rotor.
- Electrical connection via 2 leads AWG 22. Bared and tin-plated.
- Mass: 560 g.



Nominal data		Air flow	Air flow	Nominal voltage	Frequency	Sound power level	Sinter sleeve bearings Ball bearings	Power input	Nominal speed	Temperature range	Service life L <sub>10</sub> at 40 °C	at T <sub>max</sub>	Curve
Type		m <sup>3</sup> /h	CFM	V	Hz	Bel(A)	□ / ■	Watts	RPM	°C	Hours	Hours	
RG 90-18/50		54	31,8	230	50	5,8	□	22,0	2 200	-30...+60	35 000 / 20 000		1
RG 90-18/56		54	31,8	230	50	5,8	■	22,0	2 200	-30...+60	35 000 / 20 000		1
RG 90-18/00		47	27,7	115	60	6,2	□	22,0	1 900	-30...+65	35 000 / 20 000		2
RG 90-18/06		47	27,7	115	60	6,2	■	22,0	1 900	-30...+65	35 000 / 20 000		2

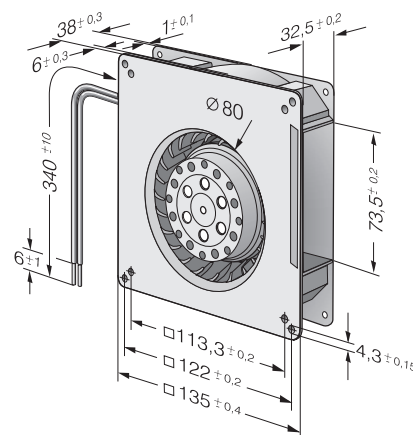
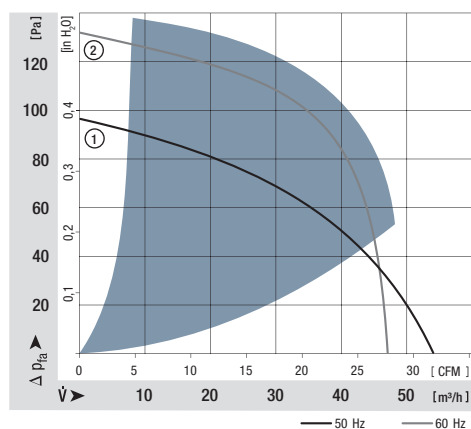

max. 94 m<sup>3</sup>/h

# AC centrifugal fans

Series RG 125 180 x 180 x 40 mm



- AC centrifugal fan with external rotor shaded-pole motor. Impedance protected against overloading.
- Spiral housing and impeller of fibreglass-reinforced plastic. Housing base of galvanised steel plate.
- Direction of air flow radial, through housing port. Direction of rotation clockwise, seen on rotor.
- Electrical connection via 2 leads AWG 22. Bared and tin-plated.
- Mass: 850 g.

Nominal data		Air flow	Air flow	Nominal voltage	Frequency	Sound power level	Sinter sleeve bearings Ball bearings	Power input	Nominal speed	Temperature range	Service life L <sub>10</sub> at 40 °C	at T <sub>max</sub>	Curve
Type		m <sup>3</sup> /h	CFM	V	Hz	Bel(A)	■ / ■	Watts	RPM	°C	Hours	Hours	
RG 125-19/56		86	50,6	230	50	5,8	■	20,0	2 550	-30...+70	37 500 / 20 000		1
RG 125-19/06		94	55,3	115	60	6,0	■	19,0	2 750	-30...+80	40 000 / 15 000		2

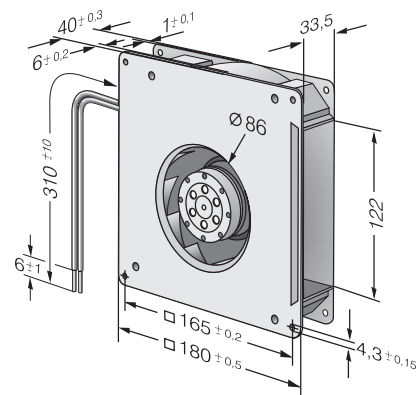
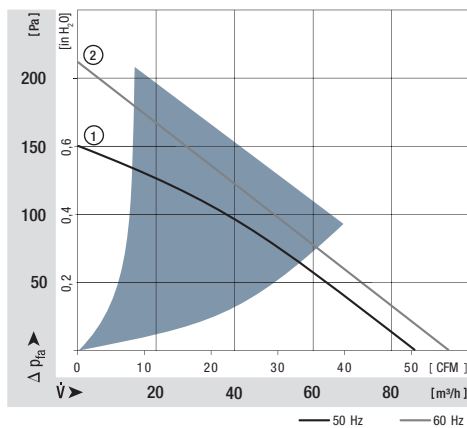

max. 223 m<sup>3</sup>/h

# AC centrifugal fans

Series RG 160 220 x 220 x 56 mm

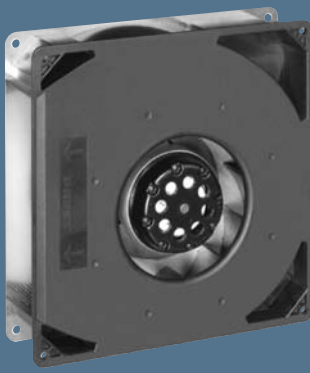

- AC centrifugal fan with external rotor shaded-pole motor. Thermal contactor as protection against thermal overloading.
- Spiral housing and impeller of fibreglass-reinforced plastic. Housing base of galvanised steel plate.
- Direction of air flow radial, through housing port. Direction of rotation counter-clockwise, seen on rotor.
- Electrical connection via leads AWG 18. Bared and tin-plated.
- Mass: 1.7 kg.

Nominal data		Air flow	Air flow	Nominal voltage	Frequency	Sound power level	Sinter sleeve bearings Ball bearings	Power input	Nominal speed	Temperature range	Service life L <sub>10</sub> at 40 °C	at T <sub>max</sub>	Curve
Type		m <sup>3</sup> /h	CFM	V	Hz	Bel(A)	■ / ■	Watts	RPM	°C	Hours	Hours	
RG 160-28/56S		202	118,9	230	50	6,6	■	47,0	2 750	-30...+70	30 000 / 15 000		1
RG 160-28/06S		223	131,3	115	60	6,9	■	50,0	3 050	-30...+80	27 500 / 12 500		2

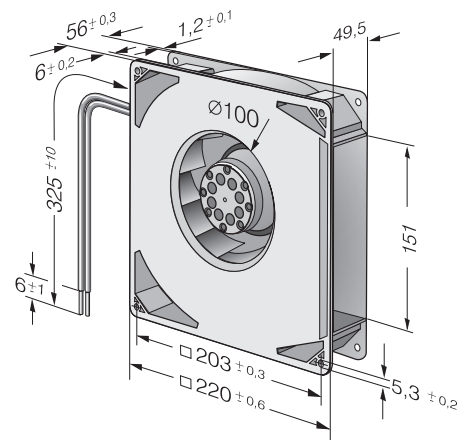
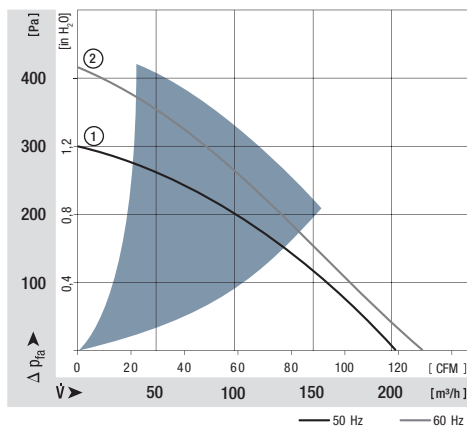

max. 115 m<sup>3</sup>/h

# AC centrifugal fans

Series RER 125 138 Ø x 40 mm



- AC centrifugal fan with external rotor shaded-pole motor. Impedance protected against overloading.
- Impeller of fibreglass-reinforced plastic, with steel plate reinforced.
- Direction of air flow radial. Direction of rotation clockwise, seen on rotor.
- Electrical connection via leads AWG 22. Bared and tin-plated.
- Mass: 500 g.

Nominal data	Air flow		Nominal voltage	Frequency	Sound power level	Sinter sleeve bearings Ball bearings	Power input	Nominal speed	Temperature range	Service life L <sub>10</sub>		Curve
	m <sup>3</sup> /h	CFM								Hours	Hours	
RER 125-19/56	104	61,2	230	50	6,2	■	19,0	2 600	-30...+60	37 500 / 22 500		1
RER 125-19/06	115	67,7	115	60	6,5	■	18,0	2 850	-30...+70	40 000 / 20 000		2

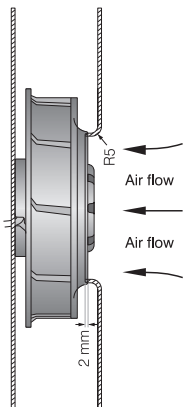

The air flow and noise level of fans without external housing depend on the installation conditions. The stated air flow and noise levels have been measured under the following conditions:  
Centrifugal fan mounted on a base plate 220 x 220 mm. Cover plate 220 x 220 mm with an air inlet of Ø 86 mm, concentric to the impeller.

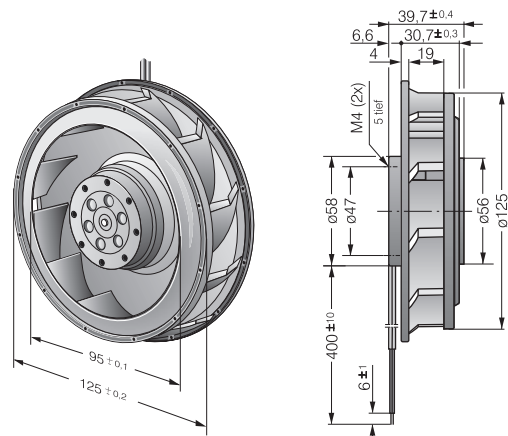
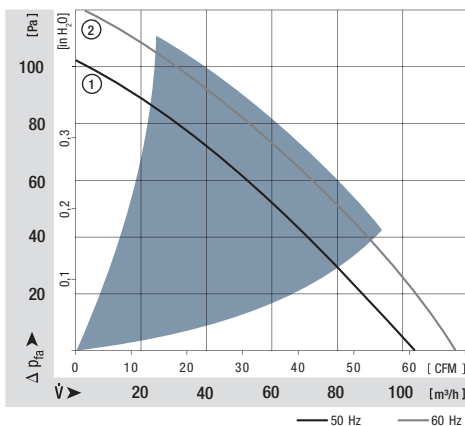

max. 274 m<sup>3</sup>/h

# AC centrifugal fans

Series RER 160 176 Ø x 54 mm



- AC centrifugal fan with external rotor shaded-pole motor. Impedance protected against overloading.
- Impeller of fibreglass-reinforced plastic, with steel plate reinforced.
- Direction of air flow radial. Direction of rotation counter-clockwise, seen on rotor.
- Electrical connection via leads AWG 18. Bared and tin-plated.
- Mass: 1.0 kg.

Nominal data	Air flow		Nominal voltage	Frequency	Sound power level	Sinter sleeve bearings Ball bearings	Power input	Nominal speed	Temperature range	Service life L <sub>10</sub>		Curve
	m <sup>3</sup> /h	CFM								at 40 °C	at T <sub>max</sub>	
Type	m <sup>3</sup> /h	CFM	V	Hz	Bel(A)	□ / ■	Watts	RPM	°C	Hours	Hours	
RER 160-28/56S	234	137,7	230	50	6,6	■	45,0	2 800	-30...+60	30 000 / 20 000		1
RER 160-28/06S	274	161,3	115	60	6,8	■	46,0	3 250	-30...+70	30 000 / 15 000		2

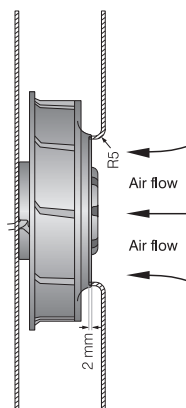

The air flow and noise level of fans without external housing depend on the installation conditions. The stated air flow and noise levels have been measured under the following conditions:  
Centrifugal fan mounted on a base plate 260 x 260 mm. Cover plate 260 x 260 mm with an air inlet of Ø 100 mm, concentric to the impeller.

