

REVISION RECORD				
REV	ECN	DESCRIPTION	DRFT	DATE

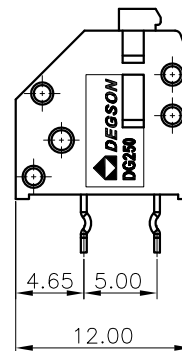
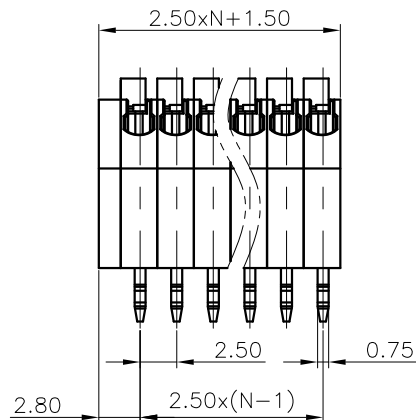
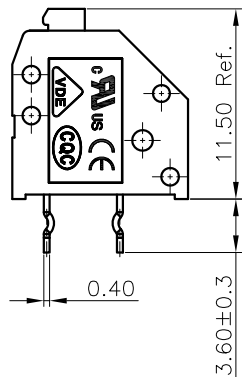

NOTES1:

UL Standard

- 1.Rated voltage/current : 300V / 2A
- 2.Wire range : 24~20AWG

IEC Standard

- 1.Rated voltage/current : 250V / 2A
- 2.Wire range : 0.2~0.5mm²

NOTES2:

- 1.Dimension shall be interpreted per ASME Y14.5-2009
- 2.Pitch : 2.50mm, Poles : N=01~XXP
- 3.Stripping length : 8-9mm
- 4.Withstanding voltage : AC2000V/1Min.
- 5.Operating temperature : -40°C~+105°C
- 6.Undimensioned tolerances:

Pitch range in mm		Nominal dimension range in mm					—	∩	□
TO	Over	Over	TO	Over	Over	Over	0.1/10		
6	6 TO 10	10 TO 24	30	30 TO 60	60 TO 100	100 TO 150	<		
±0.15	±0.20	±0.30	±0.30	±0.50	±0.70	±1.00	±1.30	±2*	

7.RoHS Compliance

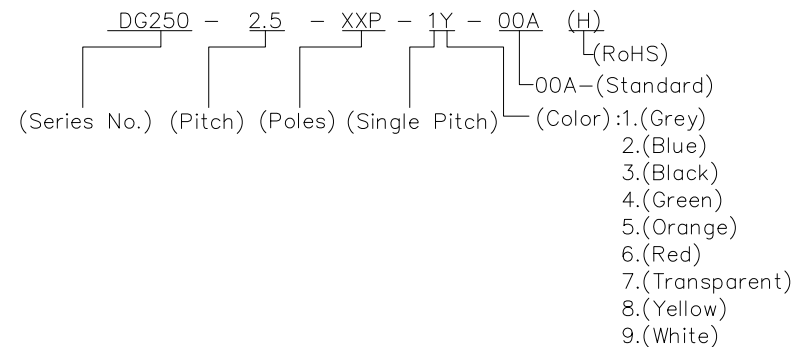
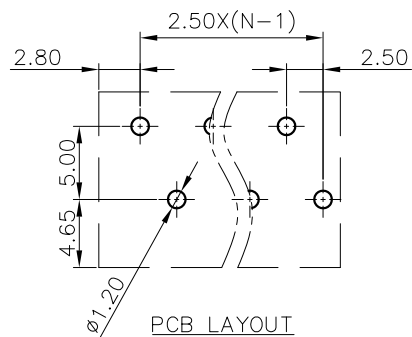

DETACHED LISTS	PART NO.:	宁波高松电子有限公司 NINGBO DEGSON ELECTRICAL CO., LTD			
	APPD:	NAME: DG250-2.5-XXP-1Y-00A(H)			
	CHKD:	TITLE: CUSTOMER DRAWING			
	DRFT:	DRAWING NO.:		REV	DO
THIRD ANGLE PROJECTION		DO NOT SCALE DRAWING	SHEET	1/1	
		MM (INCH)	SCALE	1:1	