

**SPECIFICATION**

**1. PART NUMBER**

Part Number	Packaging	Quantity	Remarks
MM8030-2610B	Bulk Package		
MM8030-2610RJ3	178mm dia. Reel	3000pcs/reel	ESD protection
MM8030-2610RK0	330mm dia. Reel	10000pcs/reel	ESD protection

**2. MECHANICAL**

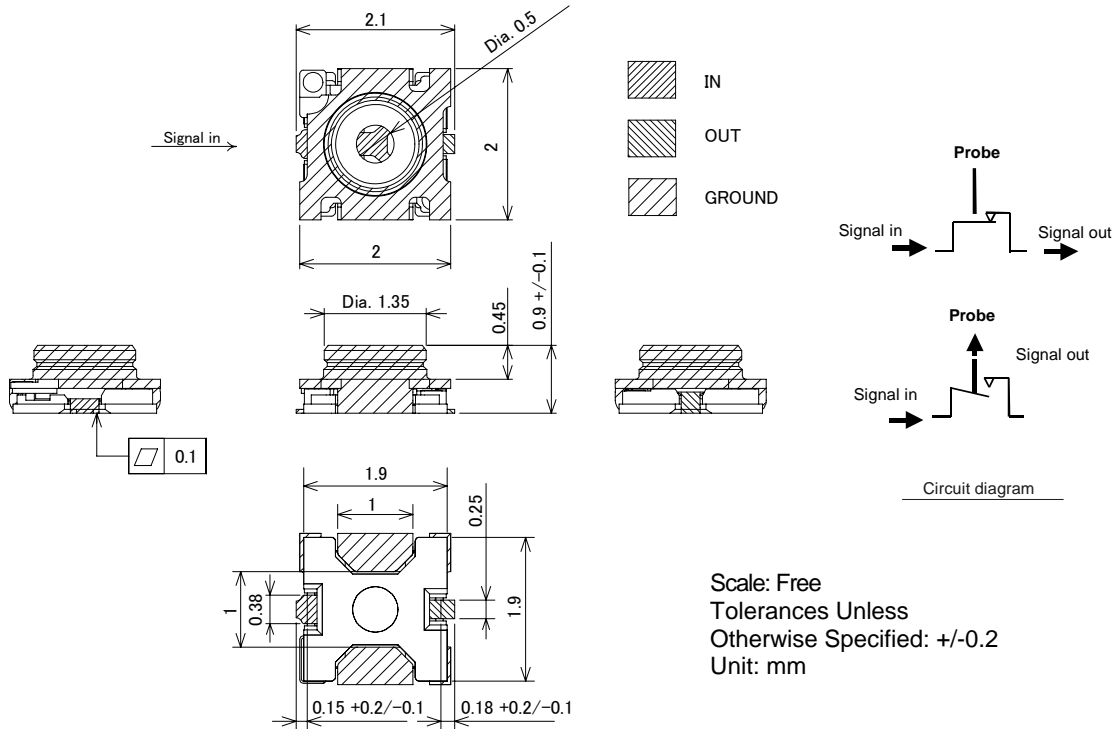
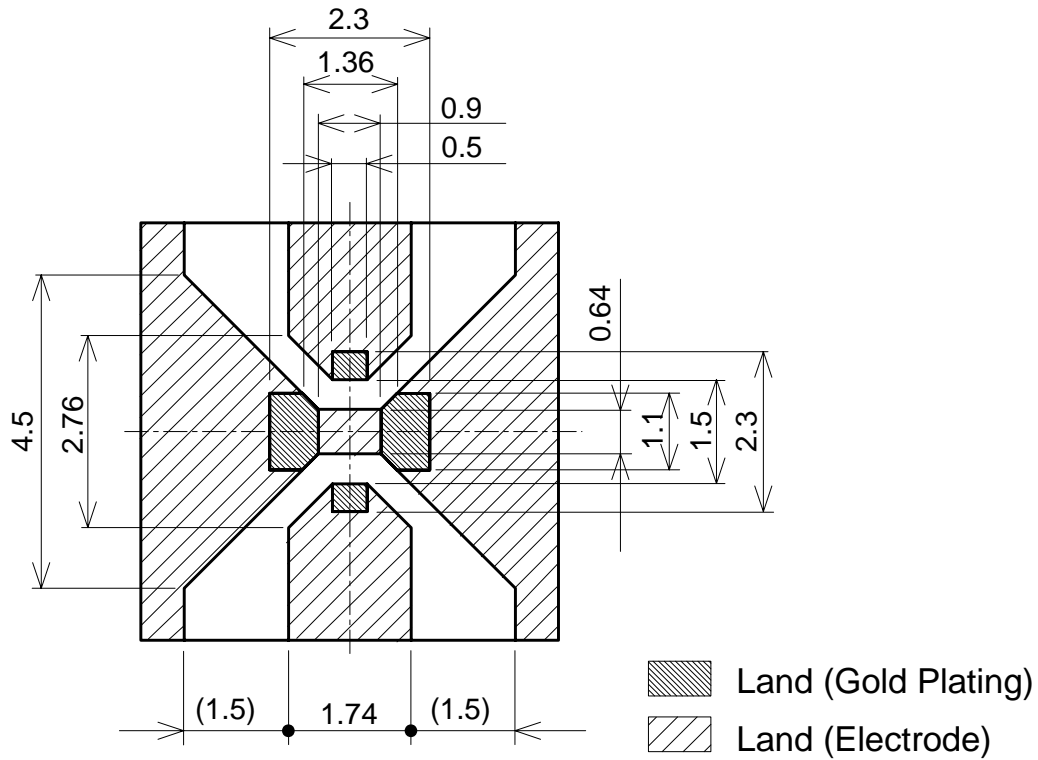

FIGURE1. Construction

**3. RATING :**

Item	Specification
Voltage Rating	250V r.m.s. maximum
Nominal Frequency Range	DC to 11GHz
Nominal Impedance	50Ω
Power Rating	2Wmax (at 2GHz)
Temperature Rating	-40°C to +85°C
Insulation Resistance	500 MΩ minimum
Withstanding Voltage	No evidence of break down in AC300+/-20Vr.m.s, 1minute
Initial Contact Resistance (without conductor resistance)	70mΩ max.
Voltage Standing Wave Ratio (V.S.W.R.)	1.2 max. (DC to 3GHz) 1.3 max. (3GHz to 6GHz) 1.5max. (6GHz to 11GHz)
Insertion Loss	0.1dBmax. (DC to 3GHz) 0.2dBmax.(3GHz to 6GHz) 0.5dBmax. (6GHz to 11GHz)
Isolation	20dBmin.(DC to 3GHz) 15dBmin.(3GHz to 6GHz) 10dBmin. (6GHz to 11GHz)
Durability	100 cycles

4. STANDARD PATTERN DIMENSION



(Note) ·The material of PWB is the epoxy resin of glass fabric base. ( $\epsilon_r=4.8$ ). Thickness is 1.0mm.

·The solder resist should be printed except for the land pattern on the PWB

FIGURE2. Standard pattern dimensions

5. STANDARD STENCIL MASK PATTERN

The standard stencil mask pattern is as FIGURE 3.(Thickness is 0.12mm)

There is the possibility to have the contact failure by solder shifting into contact point, if the excess solder is used by non standard stencil mask pattern

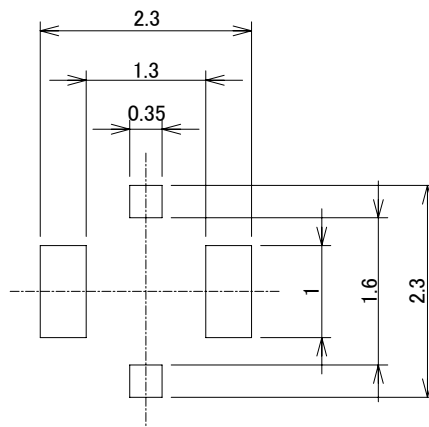

FIGURE3. Standard stencil mask pattern

6.  CAUTION

Limitation of Applications

Please do not use our products for the applications listed below which require specially high reliability for the prevention of defects which may directly or indirectly cause damage to the third party's life, body or property.

- (1) Aircraft equipment
- (2) Aerospace equipment
- (3) Undersea equipment
- (4) Power plant control equipment
- (5) Medical equipment
- (6) Transportation equipment (vehicles, trains, ships, etc.)
- (7) Traffic signal equipment
- (8) Disaster prevention / crime prevention equipment
- (9) Data-processing equipment
- (10) Application of similar complexity and/or reliability requirements to the applications listed in the above.

# Mouser Electronics

Authorized Distributor

Click to View Pricing, Inventory, Delivery & Lifecycle Information:

[Murata:](#)

[MM8030-2610RK0](#) [MM8030-2610RJ3](#)