

## SLG47115V Evaluation Board Quick Start

This user manual provides basic guidelines for developers to get familiar with the Evaluation Board for SLG47115V. It consists of the functional description of the board.

## Contents

<b>1. Terms and Definitions .....</b>	<b>2</b>
<b>2. References.....</b>	<b>2</b>
<b>3. Introduction.....</b>	<b>2</b>
<b>4. Functional Description.....</b>	<b>4</b>
4.1 Expansion Connectors and Test Points .....	4
4.1.1. Expansion Connectors SV1 and SV2 .....	4
4.1.2. Power Supply and Power Selection Connector (P5) .....	5
4.1.3. High-voltage Output Connector (P3).....	5
4.1.4. Current Measurement Shunt P1 .....	5
4.1.5. I <sup>2</sup> C Pull-Up Resistors.....	6
4.1.6. Protection Digital GND from Power GND .....	6
<b>5. Board Design.....</b>	<b>7</b>
5.1 Board Dimensions .....	7
5.2 Top View.....	8
5.3 Board Schematic .....	9
5.4 BOM.....	10
<b>6. Conclusions .....</b>	<b>10</b>
<b>7. Ordering Information.....</b>	<b>11</b>
<b>8. Revision History .....</b>	<b>11</b>

## Figures

Figure 1. SLG47115V EVB General View .....	2
Figure 2. SLG47115V EVB Connected into ADB.....	3
Figure 3. SLG47115V Evaluation Board Dimensions .....	7
Figure 4. SLG47115V Evaluation Board, Top View .....	8
Figure 5. SLG47115V Evaluation Board Schematic .....	9

## Tables

Table 1. Male Headers SV1 and SV2 Functions .....	4
Table 2. P5 Connector Functions .....	5
Table 3. P3 Connector Functions .....	5
Table 4. Jumper P1 Functions.....	6

# 1. Terms and Definitions

ADB	Advanced Development Board
EVB	Evaluation Board
PDB	Pro Development Board
TP	Test Point

# 2. References

- [1] SLG47115, Datasheet - TBD.
- [2] NXP «I2C-bus specification and user manual». User manual. UM10204–Rev.6, 4 April 2014.  
<https://www.nxp.com/docs/en/user-guide/UM10204.pdf>

# 3. Introduction

SLG47115V Evaluation Board (EVB) (see [Figure 1](#)) allows to get acquainted with SLG47115’s functionality, especially the H-Bridge/Half-Bridge functions, and allows the User to test the power part of the chip.

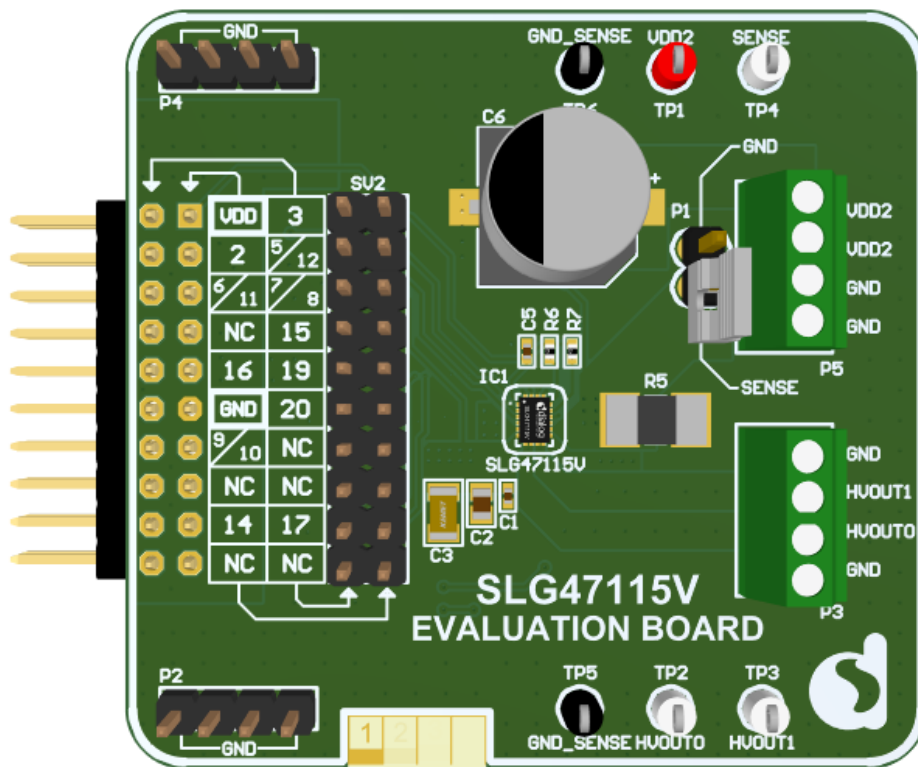

**Figure 1. SLG47115V EVB General View**

You can emulate/program the SLG47115 chip with the Advanced Development Board (ADB) or Pro Development Board (PDB). Insert EVB expansion connector SV1 into the ADB or PDB socket. In the case with PDB connect EVB expansion connector SV1 into the socket connector. The first pin locates at the right connector side. See [Figure 2](#).

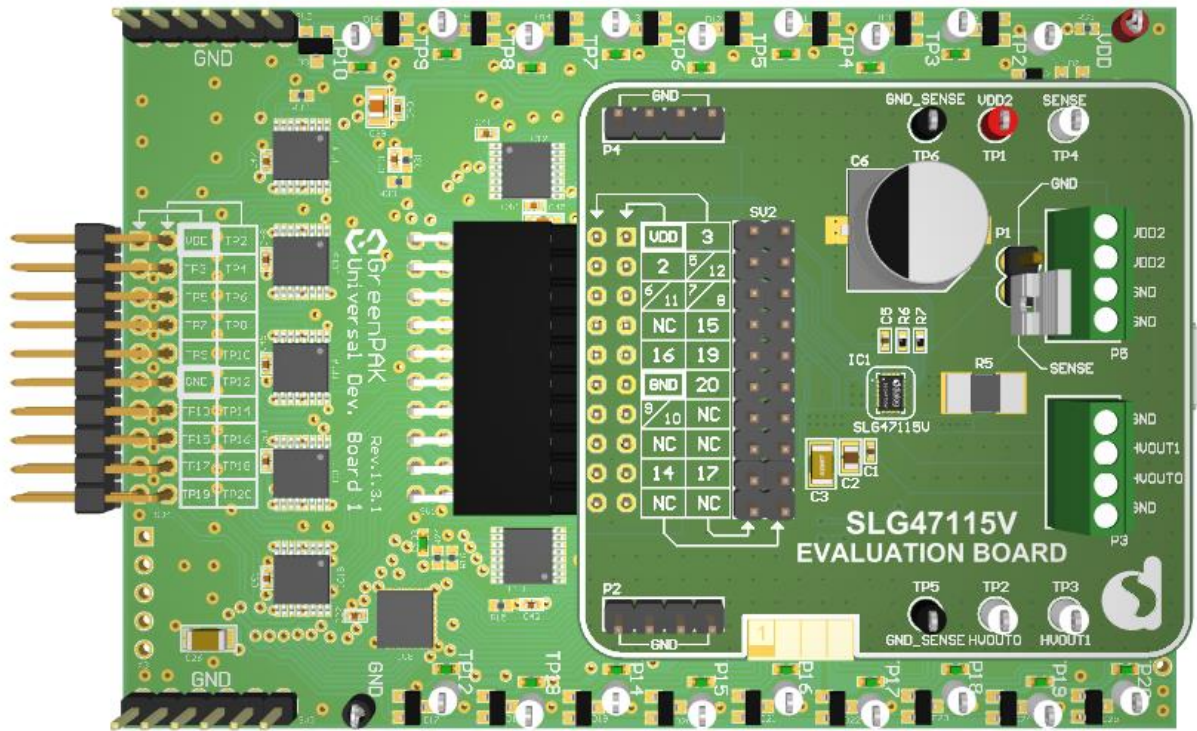

Figure 2. SLG47115V EVB Connected into ADB

## 4. Functional Description

### 4.1 Expansion Connectors and Test Points

#### 4.1.1. Expansion Connectors SV1 and SV2

There are two male headers SV1 and SV2 placed on the board.

The SV1 male header is used only to connect SLG47115V Evaluation Board to the GreenPAK Advanced Development Platform or the GreenPAK Pro Development Platform. Therefore, SV1 has a connection with Chip Low Voltage IO Pins only. High Voltage Pins 6, 7, 8, 9, 10, and 11 are not connected to SV1 by default.

**Only in case  $V_{DD} = V_{DD2}$ , it is possible to connect High Voltage Pins 6, 7, 8, 9, 10, and 11 to SV1 by installing resistors R2-R4 on the board.**

The SV2 male header has a connection with all the chip pins and can be used in the debugging process. This allows monitoring the chip functionality by connecting measuring devices (oscilloscope, voltmeter, logic analyzer) to SV2.

Male headers SV1 and SV2 functions can be found in [Table 1](#).

**Table 1. Male Headers SV1 and SV2 Functions**

Header	Marked on Board	IC Pin	Function	Notes
SV1.1 SV2.1	$V_{DD}$	Pin 1	$V_{DD}$	
SV1.2 SV2.2	3	Pin 3	GPI	
SV1.3 SV2.3	2	Pin 2	GPIO0	
SV1.4 SV2.4	5, 12	Pin 5, 12	SENSE	Connected to SV1 through 200R resistor R1
SV1.5 SV2.5	6, 11	Pin 6, 11	$HV_{DD}$	Not Connected to SV1. Connection option through resistor R2
SV1.6 SV2.6	7, 8	Pin 7, 8	$HV\_GPO0$	Not Connected to SV1. Connection option through resistor R3
SV1.7 SV2.7	NC			
SV1.8 SV2.8	15	Pin 15	GPIO2	
SV1.9 SV2.9	16	Pin 16	GPIO3	
SV1.10 SV2.10	19	Pin 19	GPIO5	
SV1.11 SV2.11	GND	Pin 18	GND	GND connected through PTC protection to SV1
SV1.12 SV2.12	20	Pin 20	GPIO6	
SV1.13 SV2.13	9, 10	Pin 9, 10	$HV\_GPO1$	Not Connected to SV1. Connection option through resistor R4
SV1.14 SV2.14	NC			
SV1.15 SV2.15	NC			
SV1.16	NC			

Header	Marked on Board	IC Pin	Function	Notes
SV2.16				
SV1.17 SV2.17	14	Pin 14	GPIO1	
SV1.18 SV2.18	17	Pin 17	GPIO4	
SV1.19 SV2.19	NC			
SV1.20 SV2.20	NC			

#### 4.1.2. Power Supply and Power Selection Connector (P5)

$V_{DD2}$  is supplied from an external power supply through the connector P5.

For P5 connector pin functions refer to [Table 2](#).

Table 2. P5 Connector Functions

Header	Marked on Board	IC Pin	Function	Notes
P5.1	$V_{DD2}$	Pin 6, 11	$V_{DD2}$	
P5.2	$V_{DD2}$	Pin 6, 11	$V_{DD2}$	
P5.3	GND			
P5.4	GND			

Using test point TP1 ( $V_{DD2}$ ) the User can control the voltage on  $V_{DD2}$  rail.

Capacitor C6 is used to decouple noise on the  $V_{DD2}$  power line. It is optional and is not board mounted by default. It is possible to install it by the User independently, for example, when testing a high-power motor close to the chip maximum capabilities.

#### 4.1.3. High-voltage Output Connector (P3)

The connector P3 is used for connecting the electric motor or another high-power load powered by  $V_{DD2}$ . For P3 connector pin functions see [Table 3](#).

Table 3. P3 Connector Functions

Header	Marked on board	IC Pin	Function	Notes
P3.1	GND	Pin 4, 13	GND	Test point TP5, TP6
P3.2	HVOUT1	Pin 9, 10	HV_GPO 1	Test point TP3 (HVOUT1) mounted on board
P3.3	HVOUT0	Pin 7, 8	HV_GPO 0	Test point TP2 (HVOUT0) mounted on board
P3.4	GND	Pin 4, 13	GND	Test point TP5, TP6

Test points TP2 (HVOUT0), TP3 (HVOUT1) make possible controlling the output signals.

#### 4.1.4. Current Measurement Shunt P1

Resistor R5 is connected to the input SENSE (Pin 5, 12) of the Current Sense Comparator macrocells, which allow controlling the load current of each H-Bridge. This function can be switch on/off with the help of Jumper P1.

Jumper P1 functions can be found in [Table 4](#).

Table 4. Jumper P1 Functions

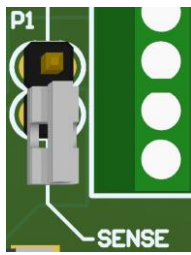
Jumper	Marked on Board	IC Pin	Function	Notes
P1		Pin 5, 12	Connect SENSE to GND	<p>OPEN – Current Sense Comparator0 current control function is turned on</p> <p>CLOSED – Current Sense Comparator0 current control function is turned off</p>

It is possible to control voltage on resistor R5 by connecting measuring devices (voltmeter, oscilloscope) to the test point TP4 (SENSE), installed on the board.

Also, there are two test points TP5, TP6 (GND\_SENSE) installed on the board. They are connected to Pin 4 (GND) and Pin 13 (GND) and can be used for measurements **only**.

#### 4.1.5. I<sup>2</sup>C Pull-Up Resistors

If the board is not connected to the GreenPAK Advanced Development Platform or the GreenPAK Pro Development Platform and used separately, for example, with a programmed chip for debugging in the final production, two pull-up resistors, R6 and R7 for SDA and SCL, should be installed on the board. Their resistance should be calculated according to the procedure described in Reference [2] (Section 2 [References](#)).

#### 4.1.6. Protection Digital GND from Power GND

PTC1 is used for protecting digital GND from power GND (HV\_GND). The maximum current that can flow from power GND through PTC1 to digital GND pin is limited to 50 mA.

## 5. Board Design

### 5.1 Board Dimensions

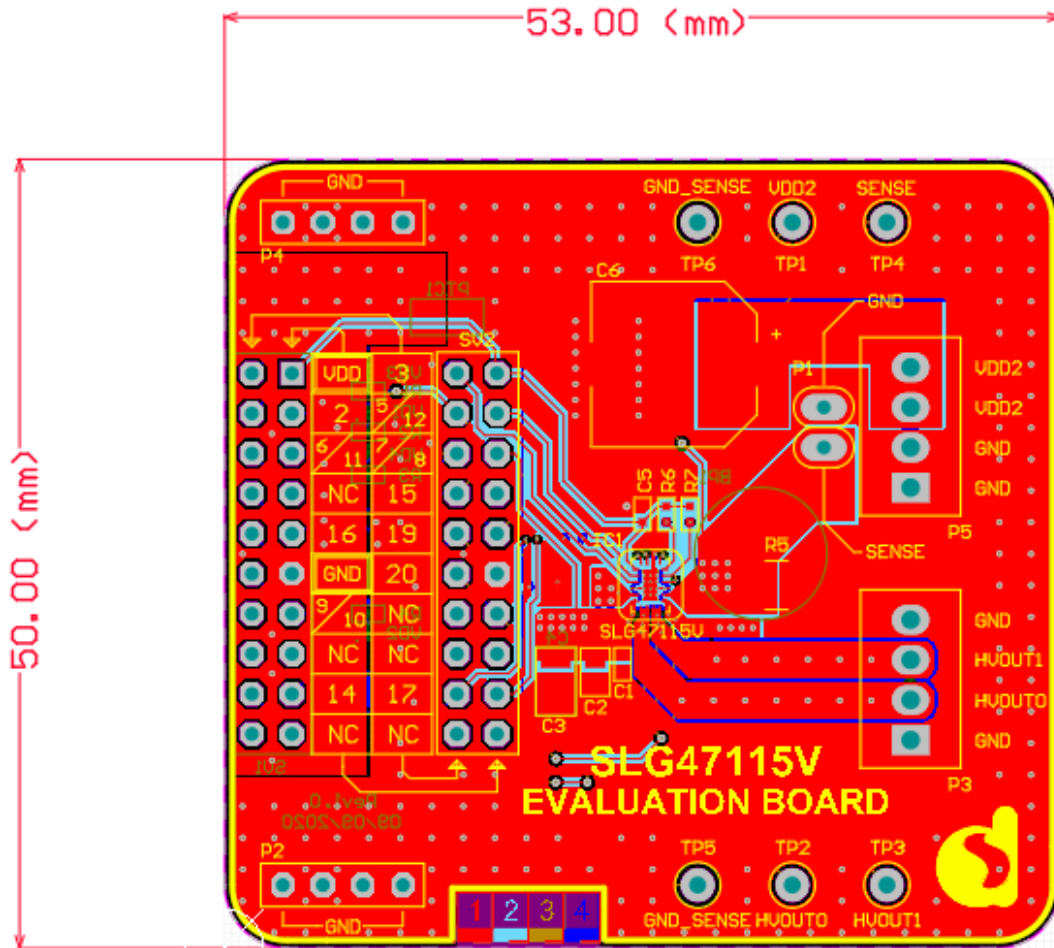

Figure 3. SLG47115V Evaluation Board Dimensions

## 5.2 Top View

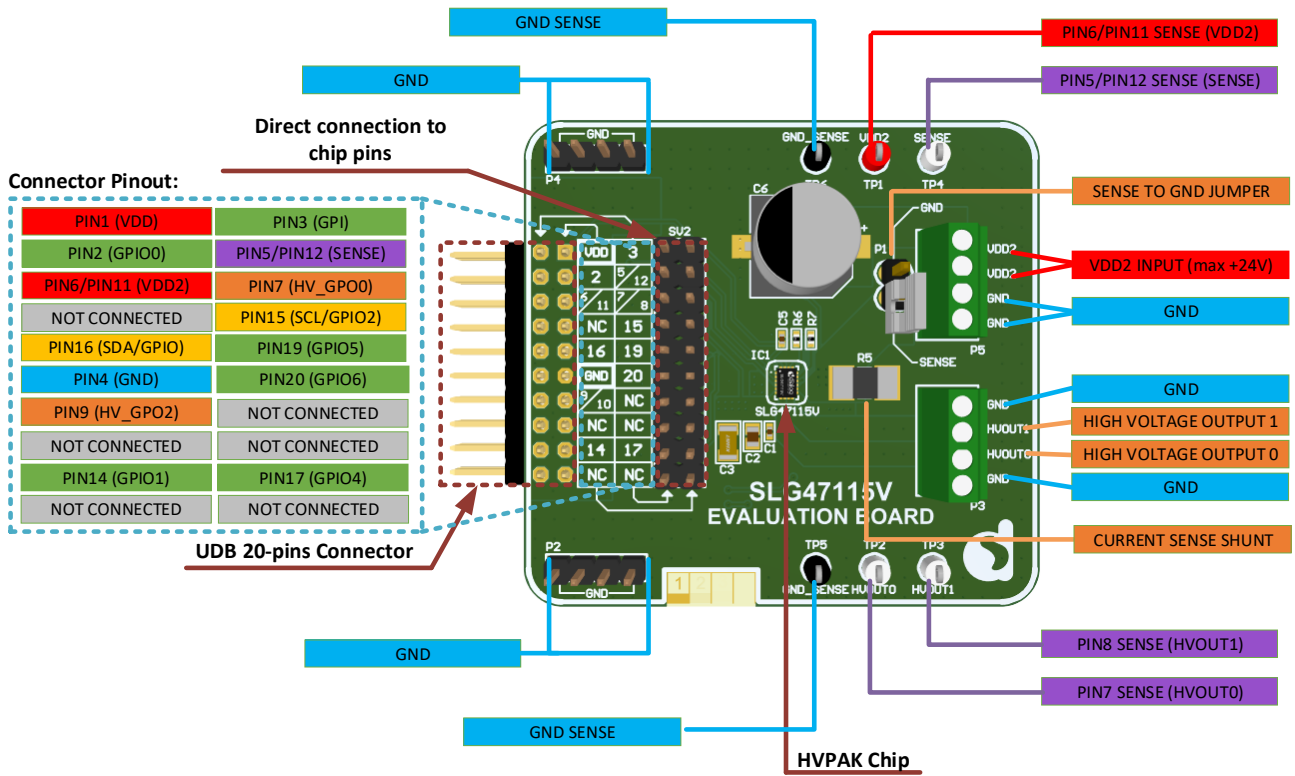

Figure 4. SLG47115V Evaluation Board, Top View



### 5.3 Board Schematic

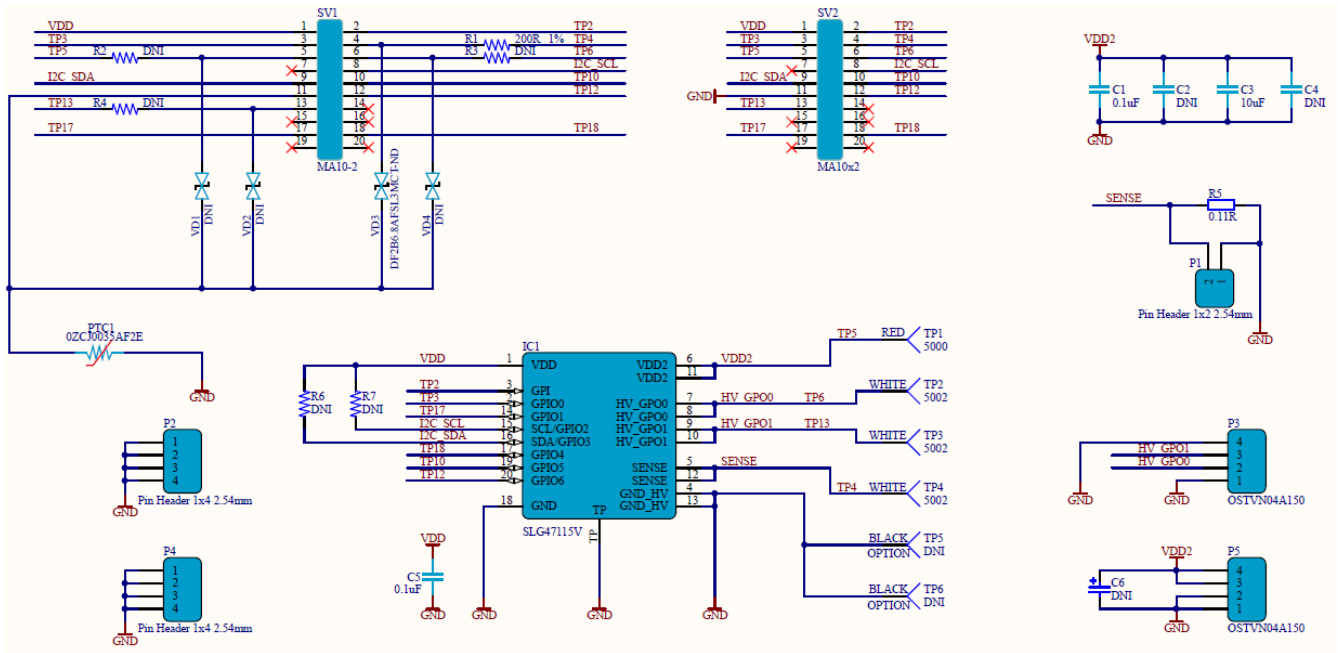

Figure 5. SLG47115V Evaluation Board Schematic

## 5.4 BOM

#	Designator	Description	Manufacturer Part Number	Footprint	Quantity
1	BP1	BUMPER CYLIN 0.312" DIA BLK	70006431426		1
2	C1, C5	CAP CER 0.1UF 50V X7R 0402	C1005X7R1H104K050BB	C0402	2
3	C2, C4	DNI		C0805, C1206	2
4	C3	CAP CER 10UF 50V X5R 1206	CL31A106KBHNNNE	C1206	1
5	C6	DNI		Size code: G	1
6	IC1	PROGRAMMABLE MIXED-SIGNAL MATRIX WITH H-BRIDGE FUNCTIONS	SLG47105V	STQFN-20-2.0X3.0	1
7	JP1	CONN JUMPER SHORTING 2.54mm GOLD	NPC02SXON-RC		1
8	P1	CONN HEADER VERT 2POS 2.54mm	5-146268-1	1x2 2.54mm	1
9	P2, P4	CONN HEADER VERT 4POS 2.54mm	61300411121	1x4 2.54mm	2
10	P3, P5	TERM BLK 4P SIDE ENT 2.54mm PCB	OSTVN04A150	1x4 2.54mm	2
11	PTC1	PTC RESET FUSE 30V 350MA 1206	0ZCJ0035AF2E	PTC1206	1
12	R1	RES 200 OHM 1% 1/16W 0402	CRCW0402200RFKED	R0402	1
13	R2, R3, R4	DNI		R0402	3
14	R5	RES 0.11 OHM 1% 1/2W 2010	WSL2010R1100FEA	R2512	1
15	R6, R7	DNI		R0402	2
16	SV1	CONN HEADER VERT 10POS 2.54mm	68021-220HLF	1x10 2.54mm	1
17	SV2	CONN HEADER VERT 10POS 2.54mm	67996-420HLF	1x10 2.54mm	1
18	TP1	PC TEST POINT MINIATURE RED	5000	Hole Diameter(1.02mm)	1
19	TP2, TP3, TP4	PC TEST POINT MINIATURE WHITE	5002	Hole Diameter(1.02mm)	3
20	TP5, TP6	DNI		Hole Diameter(1.02mm)	2
21	VD1, VD2, VD4	DNI	DF2B6.8AFS, L3M	SOD-923	3
22	VD3	TVS DIODE 5V 7V FSC		SOD-923	1

## 6. Conclusions

Evaluation Board has been designed as a high power debugging platform for SLG47115V. It is a convenient tool that allows the customer to get acquainted with SLG47115's functionality, especially the H-Bridge functions.

## 7. Ordering Information

Part Number	Description
SLG47115V-EVB	Evaluation Board for SLG47115V. Developed for testing designs with all features and high current loads.

## 8. Revision History

Revision	Date	Description
1.00	May 5, 2022	Initial release

## Notice

1. Descriptions of circuits, software and other related information in this document are provided only to illustrate the operation of semiconductor products and application examples. You are fully responsible for the incorporation or any other use of the circuits, software, and information in the design of your product or system. Renesas Electronics disclaims any and all liability for any losses and damages incurred by you or third parties arising from the use of these circuits, software, or information.
2. Renesas Electronics hereby expressly disclaims any warranties against and liability for infringement or any other claims involving patents, copyrights, or other intellectual property rights of third parties, by or arising from the use of Renesas Electronics products or technical information described in this document, including but not limited to, the product data, drawings, charts, programs, algorithms, and application examples.
3. No license, express, implied or otherwise, is granted hereby under any patents, copyrights or other intellectual property rights of Renesas Electronics or others.
4. You shall be responsible for determining what licenses are required from any third parties, and obtaining such licenses for the lawful import, export, manufacture, sales, utilization, distribution or other disposal of any products incorporating Renesas Electronics products, if required.
5. You shall not alter, modify, copy, or reverse engineer any Renesas Electronics product, whether in whole or in part. Renesas Electronics disclaims any and all liability for any losses or damages incurred by you or third parties arising from such alteration, modification, copying or reverse engineering.
6. Renesas Electronics products are classified according to the following two quality grades: "Standard" and "High Quality". The intended applications for each Renesas Electronics product depends on the product's quality grade, as indicated below.

"Standard": Computers; office equipment; communications equipment; test and measurement equipment; audio and visual equipment; home electronic appliances; machine tools; personal electronic equipment; industrial robots; etc.

"High Quality": Transportation equipment (automobiles, trains, ships, etc.); traffic control (traffic lights); large-scale communication equipment; key financial terminal systems; safety control equipment; etc.

Unless expressly designated as a high reliability product or a product for harsh environments in a Renesas Electronics data sheet or other Renesas Electronics document, Renesas Electronics products are not intended or authorized for use in products or systems that may pose a direct threat to human life or bodily injury (artificial life support devices or systems; surgical implantations; etc.), or may cause serious property damage (space system; undersea repeaters; nuclear power control systems; aircraft control systems; key plant systems; military equipment; etc.). Renesas Electronics disclaims any and all liability for any damages or losses incurred by you or any third parties arising from the use of any Renesas Electronics product that is inconsistent with any Renesas Electronics data sheet, user's manual or other Renesas Electronics document.

7. No semiconductor product is absolutely secure. Notwithstanding any security measures or features that may be implemented in Renesas Electronics hardware or software products, Renesas Electronics shall have absolutely no liability arising out of any vulnerability or security breach, including but not limited to any unauthorized access to or use of a Renesas Electronics product or a system that uses a Renesas Electronics product. RENESAS ELECTRONICS DOES NOT WARRANT OR GUARANTEE THAT RENESAS ELECTRONICS PRODUCTS, OR ANY SYSTEMS CREATED USING RENESAS ELECTRONICS PRODUCTS WILL BE INVULNERABLE OR FREE FROM CORRUPTION, ATTACK, VIRUSES, INTERFERENCE, HACKING, DATA LOSS OR THEFT, OR OTHER SECURITY INTRUSION ("Vulnerability Issues"). RENESAS ELECTRONICS DISCLAIMS ANY AND ALL RESPONSIBILITY OR LIABILITY ARISING FROM OR RELATED TO ANY VULNERABILITY ISSUES. FURTHERMORE, TO THE EXTENT PERMITTED BY APPLICABLE LAW, RENESAS ELECTRONICS DISCLAIMS ANY AND ALL WARRANTIES, EXPRESS OR IMPLIED, WITH RESPECT TO THIS DOCUMENT AND ANY RELATED OR ACCOMPANYING SOFTWARE OR HARDWARE, INCLUDING BUT NOT LIMITED TO THE IMPLIED WARRANTIES OF MERCHANTABILITY, OR FITNESS FOR A PARTICULAR PURPOSE.
8. When using Renesas Electronics products, refer to the latest product information (data sheets, user's manuals, application notes, "General Notes for Handling and Using Semiconductor Devices" in the reliability handbook, etc.), and ensure that usage conditions are within the ranges specified by Renesas Electronics with respect to maximum ratings, operating power supply voltage range, heat dissipation characteristics, installation, etc. Renesas Electronics disclaims any and all liability for any malfunctions, failure or accident arising out of the use of Renesas Electronics products outside of such specified ranges.
9. Although Renesas Electronics endeavors to improve the quality and reliability of Renesas Electronics products, semiconductor products have specific characteristics, such as the occurrence of failure at a certain rate and malfunctions under certain use conditions. Unless designated as a high reliability product or a product for harsh environments in a Renesas Electronics data sheet or other Renesas Electronics document, Renesas Electronics products are not subject to radiation resistance design. You are responsible for implementing safety measures to guard against the possibility of bodily injury, injury or damage caused by fire, and/or danger to the public in the event of a failure or malfunction of Renesas Electronics products, such as safety design for hardware and software, including but not limited to redundancy, fire control and malfunction prevention, appropriate treatment for aging degradation or any other appropriate measures. Because the evaluation of microcomputer software alone is very difficult and impractical, you are responsible for evaluating the safety of the final products or systems manufactured by you.
10. Please contact a Renesas Electronics sales office for details as to environmental matters such as the environmental compatibility of each Renesas Electronics product. You are responsible for carefully and sufficiently investigating applicable laws and regulations that regulate the inclusion or use of controlled substances, including without limitation, the EU RoHS Directive, and using Renesas Electronics products in compliance with all these applicable laws and regulations. Renesas Electronics disclaims any and all liability for damages or losses occurring as a result of your noncompliance with applicable laws and regulations.
11. Renesas Electronics products and technologies shall not be used for or incorporated into any products or systems whose manufacture, use, or sale is prohibited under any applicable domestic or foreign laws or regulations. You shall comply with any applicable export control laws and regulations promulgated and administered by the governments of any countries asserting jurisdiction over the parties or transactions.
12. It is the responsibility of the buyer or distributor of Renesas Electronics products, or any other party who distributes, disposes of, or otherwise sells or transfers the product to a third party, to notify such third party in advance of the contents and conditions set forth in this document.
13. This document shall not be reprinted, reproduced or duplicated in any form, in whole or in part, without prior written consent of Renesas Electronics.
14. Please contact a Renesas Electronics sales office if you have any questions regarding the information contained in this document or Renesas Electronics products.

(Note1) "Renesas Electronics" as used in this document means Renesas Electronics Corporation and also includes its directly or indirectly controlled subsidiaries.

(Note2) "Renesas Electronics product(s)" means any product developed or manufactured by or for Renesas Electronics.

(Rev.5.0-1 October 2020)

## Corporate Headquarters

TOYOSU FORESIA, 3-2-24 Toyosu,  
Koto-ku, Tokyo 135-0061, Japan  
[www.renesas.com](http://www.renesas.com)

## Trademarks

Renesas and the Renesas logo are trademarks of Renesas Electronics Corporation. All trademarks and registered trademarks are the property of their respective owners.

## Contact information

For further information on a product, technology, the most up-to-date version of a document, or your nearest sales office, please visit:  
[www.renesas.com/contact/](http://www.renesas.com/contact/)