

The information provided herein is from CONNFLY Electronic Co., Ltd. and is confidential. Any disclosure to a party other than the recipient is prohibited. The intellectual properties and its rights contained herein, including but not limited to, trademarks, patents, copyrights, trade secrets, and technical know-how, are owned exclusively by CONNFLY or its affiliates. Unauthorized use or modification is strictly prohibited. CONNFLY may enforce its intellectual property rights at its own discretion; failures or delays to exercise such rights does not constitute a waiver of such rights.

1                      2                      3                      4                      5                      6                      7                      8

REV.	DESCRIPTION	DRAWN	CHECKED	APPROVED
A	NEW RELEASE	HP 07/12/05'		LJC 07/12/05'
B	CHANGE THE DIM	YCH 08/17/13'		LJC 08/17/13'
C	DRAWING UPDATE	JLZ 07/17/18'		

TECHNICAL DATA

- MATERIAL
  - . Pin (Outer Sleeve): Brass, Machined, CuZn38Pb2
  - . Clip: Copper alloy, Heat Treated
- ELECTRICAL
  - . Current Rating: 3A Per Pin max.
  - . Contact Resistance:  $\leq 20m\Omega$ /Contact.

- MECHANICAL
  - . \*Average Insertion Force With Steel Pin of  $\phi 0.43mm/0.017"$ :  
4-Finger  $\leq 270g$
  - . \*Average Withdrawal Force With Steel Pin of  $\phi 0.50mm/0.020"$ :  
4-Finger  $\geq 25g$
  - . \*Mechanical Life: min 200 Cycles

4. PRODUCT NUMBER CODE:

DS1005-09 - X X X

- CLIP PLATED
  - 6: Full Tin
  - 8: Full Gold flash
  - C: Full Gold 3u"
  - A: Full Gold 10u"
  - B: Full Gold 15u"
- PIN PLATED
  - 6: Full Tin
  - 8: Full Gold flash
  - C: Full Gold 3u"
  - A: Full Gold 10u"
  - B: Full Gold 15u"
- CLIPS
  - 4: 4Finger
- SERIES NO  
DS1005-09

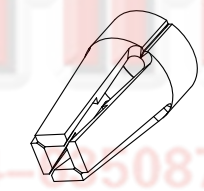
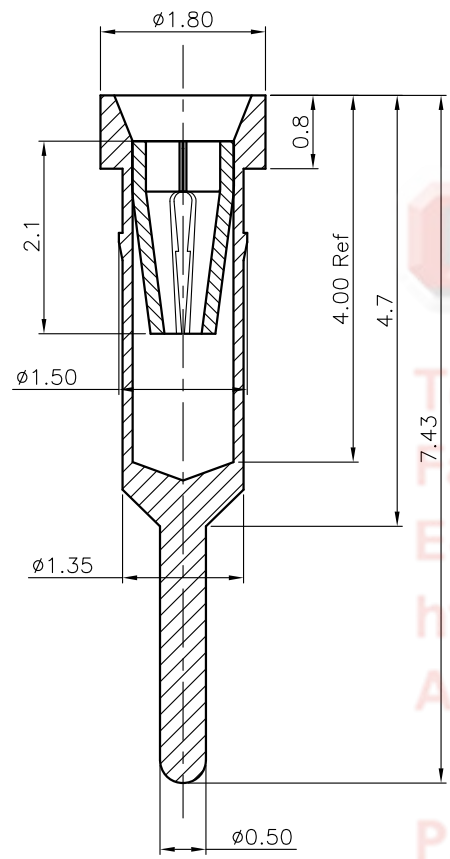

clip figure(4 fingers)

Tel:86-574-83508787  
 Fax:86-574-63510817  
 E-mail:sale@connfly.com  
 http://www.connfly.com  
 Add:East Industry Zone KuangYan  
 Town Cixi Ningbo China  
 P.C:315300

GENERAL TOLERANCE		ANGLE TOLERANCE		PROJECTION		TITLE	SOCKET TERMINALS 7.43mm	
X.	$\pm 0.60$	X.	$\pm 5^\circ$	UNITS	mm			
.X	$\pm 0.38$	.X	$\pm 3^\circ$	SHEET SIZE	A4	SERIES	DS1005-09 SERIES	
.XX	$\pm 0.25$	.XX	$\pm 2^\circ$	<b>晨翔电子有限公司</b> <b>CONNFLY CONNFLY ELECTRONIC CO. LTD</b>				
DRAWING TYPE		CUSTOMER						
SCALE		1:1	SHEET 1 OF 1					
DRAWING NO.		C-DS1005-09-XXX-C						

1                      2                      3                      4                      5                      6                      7                      8