

ITEM	DESCRIPTION	MATERIAL	FINISH
1	FRAME	ZINC DIECAST	NICKEL
2	REAR HOLDER	GF PA6	BLACK
		BRASS	SELF COLOUR
3	VGA INSERT	ABS	BLACK
		BRASS	SELF COLOUR
		STEEL	NICKEL PLATE
4	SCREWS	STEEL	BLACK

ISS.	AMEND	DATE
1	ISSUED	28/09/20

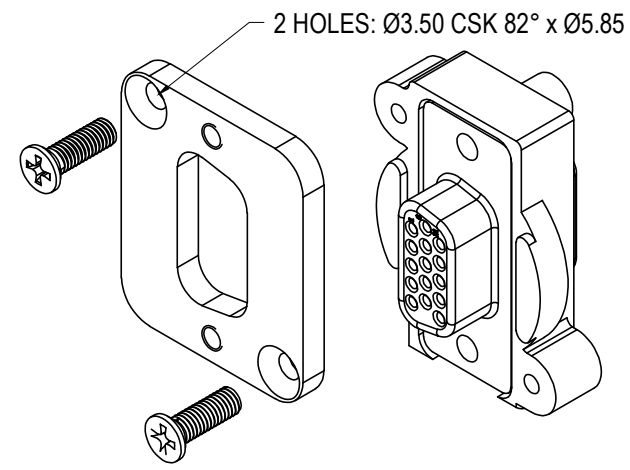
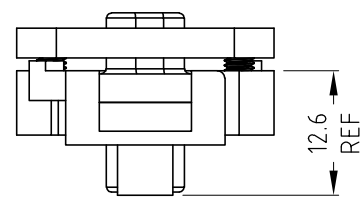
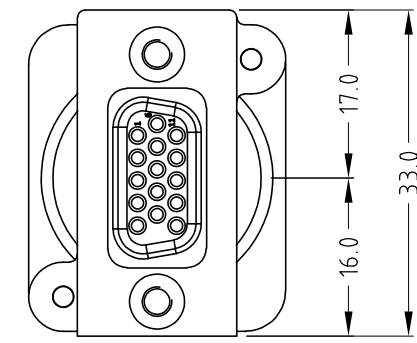
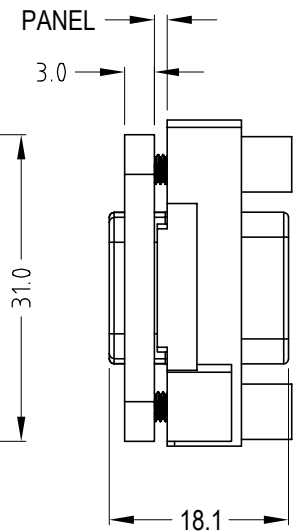
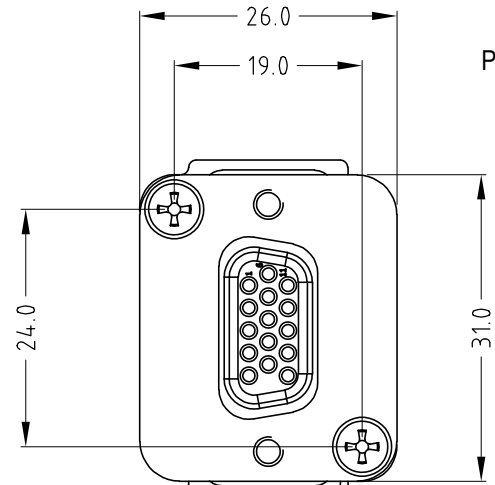
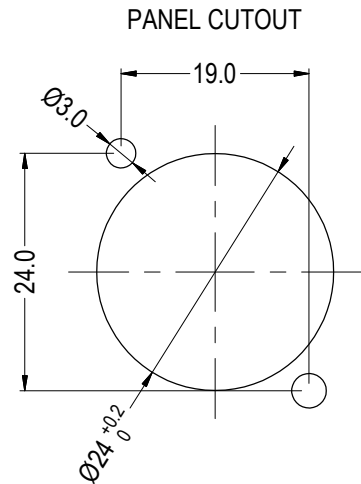

RoHS
COMPLIANT

TOLERANCE
 NO DEC. PLACE ±
 1 DEC. PLACE ±
 2 DEC. PLACE ±
 HOLE Ø ±
 ANGLES ±
 UNLESS OTHERWISE STATED

Cliff Electronic Components Ltd.
 76 Holmethorpe Avenue, Holmethorpe Industrial Estate,
 Redhill, Surrey, RH1 2PF, England, UK
 Tel: 01737-771375 Fax: 01737-766012 Website: www.cliffuk.co.uk

DIMENSIONS IN MILLIMETERS UNLESS OTHERWISE STATED. WORK TO DIMENSIONS. REMOVE ALL BURRS. IF IN DOUBT ASK.

3rd ANGLE PROJECTION:

DO NOT SCALE

MATERIAL: SEE TABLE
 FINISH: SEE TABLE

TITLE: FT VGA 15 PIN F-F METAL

THE CONTENTS OF THIS DOCUMENT MUST NOT BE COPIED OR DISCLOSED TO A 3rd PARTY WITHOUT WRITTEN PERMISSION OF CLIFF UK. © 2020

DRAWN: T.J.O.

APPROVED: D.P.J.

DRWG. No. **CP30229M** FORM: A4DRWGH