

6240-xxxx

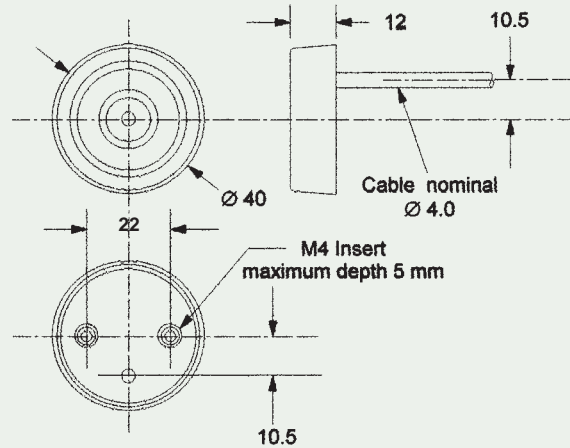

Benefits

- ❖ Waterproof to IP67
- ❖ Lightweight operation over the entire top surface
- ❖ Designed to withstand heavy loads

6240-xxxx

Low profile tactile switch

Single Pole Normally Open contact

50 mAmps @ 30V dc

Straight or Coiled Options
2 core cable - 50 mA (0.22mm²)

0°C to +60°C

Base	Black Rigid PVC
------	-----------------

Bellows	Black or Grey Flexible PVC
---------	----------------------------

Other bellows colours are available for OEM applications